

Gen4

Applications  
Reference  
Manual

Document no:

177/52701

Rev. 3.3



Partner with Performance™

Sevcon Ltd  
Kingsway South  
Gateshead. NE11 0QA  
England  
Tel +44 (0)191 497 9000  
Fax +44 (0)191 482 4223  
sales.uk@sevcon.com

Sevcon, Inc.  
155 Northboro Road  
Southborough, MA 01772  
USA  
Tel +1 (508) 281 5500  
Fax +1 (508) 281 5341  
sales.us@sevcon.com

Sevcon SAS  
Parc d'Activité du Vert Galant  
Rue Saint Simon  
St Ouen l'Aumône  
95041 Cergy Pontoise Cedex  
France  
Tel +33 (0)1 34 30 35 00  
Fax +33 (0)1 34 21 77 02  
sales.fr@sevcon.com

Sevcon Japan K.K.  
Kansai Office 51-26 Ohyabu  
Hikone  
Shiga Japan 522-0053  
Tel +81 (0) 7 49465766  
jp.info@sevcon.com

Sevcon Asia Ltd  
Room No.202  
Dong-Ah Heights Bldg  
449-1 Sang-Dong Wonmi-Gu  
Bucheon City Gyeonggi-Do  
420-816 Korea  
Tel +82 32 215 5070  
sales.kr@sevcon.com

Sevcon Germany  
Hintere Str.32  
73266 Bissingen an der Teck  
Germany  
Tel: +49 (0)170 9980294  
de.info@sevcon.com

[www.sevcon.com](http://www.sevcon.com)

# Table of Contents

## Chapter 1: Introduction 1-1

---

About Gen4 documentation .....	1-2
This version of the manual.....	1-2
Copyright.....	1-2
Scope of this manual .....	1-2
Related documents.....	1-2
Drawings and units .....	1-2
Dangers, Warnings, Cautions and Notes .....	1-3
Product identification label.....	1-4
Technical support .....	1-4
Product warranty .....	1-4

## Chapter 2: About the Gen4 2-1

---

Introduction.....	2-2
Standard features and capabilities.....	2-2
Available options.....	2-2
Intended use of the Gen4 .....	2-3
Available accessories .....	2-3
Overview of a truck drive system .....	2-4
Principles of operation .....	2-5
Functional description.....	2-5
Interfaces .....	2-6
Master-slave operation .....	2-6
Torque mode .....	2-7
Speed mode .....	2-7
Safety and protective functions.....	2-8
General .....	2-8
On-Highway Vehicles .....	2-10
Fault detection and handling.....	2-12

## Chapter 3: Installation 3-1

---

<b>Mounting Gen4</b> .....	<b>3-2</b>
Location .....	3-2
Protection from chemical contamination .....	3-2
Orientation .....	3-2
Clearance for LED access .....	3-2
Mounting hole pattern .....	3-3
Equipment required: .....	3-3
Thermal grease application .....	3-3
<b>Cooling requirements</b> .....	<b>3-5</b>
<b>EMC guidelines</b> .....	<b>3-6</b>
General measures .....	3-6
Measures required for specific signals .....	3-7
Additional measures .....	3-7
Problems to avoid .....	3-8
<b>Connecting power cables</b> .....	<b>3-9</b>
Battery and motor connections .....	3-9
Cable sizes .....	3-10
<b>On-board fuse mounting</b> .....	<b>3-11</b>
Fuse rating and selection .....	3-12
<b>Signal wiring</b> .....	<b>3-13</b>
Signal wire sizes .....	3-13
CANbus termination .....	3-13
<b>Signal connections</b> .....	<b>3-14</b>

## Chapter 4: Specification 4-1

---

<b>Electrical</b> .....	<b>4-2</b>
Input voltage .....	4-2
Output protection .....	4-2
Output ratings .....	4-4
CAN interface .....	4-5
Control inputs and outputs .....	4-5

Isolation.....	4-6
EMC .....	4-7
Regulatory compliance .....	4-7
<b>Mechanical .....</b>	<b>4-8</b>
Operating environment .....	4-8
Shock and vibration .....	4-8
Controller weight.....	4-8
Dimensions .....	4-9
Size 2 models .....	4-9
Size 4 models .....	4-9
Size 6 models .....	4-10

---

## Chapter 5:    System design 5-1

<b>Sizing a motor .....</b>	<b>5-2</b>
Information required about the application .....	5-2
Motor maximum speed .....	5-2
Torque required between zero and base speed.....	5-2
Torque required at maximum speed.....	5-3
Continuous power rating.....	5-3
Peak power rating.....	5-4
<b>Selecting the correct Gen4 model.....</b>	<b>5-4</b>
Current and power ratings considerations.....	5-4
Power output restrictions at motor and drive operating temperature limits .....	5-4
Circuit configuration .....	5-5
Single traction wiring diagram.....	5-6
Single pump wiring diagram .....	5-7
<b>Twin motor systems.....</b>	<b>5-8</b>
<b>Auxiliary components .....</b>	<b>5-8</b>
Main contactor .....	5-8
35 Way AMPSeal Connector Kit.....	5-8
Emergency stop switch.....	5-8
On-board fuse .....	5-9
Key switch fuse F2.....	5-11
Motor speed sensor (encoder) .....	5-11

Motor commutation sensor .....	5-12
<b>Initial power up sequence .....</b>	<b>5-15</b>
Checks prior to power up .....	5-15
Checks after power is applied .....	5-15
<b>Chapter 6: Configuration .....</b>	<b>6-1</b>
<hr/>	
<b>Introduction.....</b>	<b>6-2</b>
<b>DVT configuration tool .....</b>	<b>6-2</b>
DVT functionality.....	6-2
Saving, duplicating and restoring a node's configuration .....	6-2
Data Logging.....	6-3
<b>CANopen.....</b>	<b>6-3</b>
CANopen protocol .....	6-3
Object Dictionary .....	6-4
Communication objects .....	6-4
Network Configuration .....	6-5
<b>Configuration process overview.....</b>	<b>6-7</b>
Access authorization.....	6-7
How NMT state affects access to parameters.....	6-7
<b>Motor characterization .....</b>	<b>6-8</b>
Determining motor parameters .....	6-8
Self characterization .....	6-9
Additional Motor Configuration .....	6-10
<b>I/O configuration .....</b>	<b>6-11</b>
Object mapping.....	6-11
Encoder.....	6-14
Digital inputs .....	6-14
Analogue inputs .....	6-14
Analogue (contactor) outputs.....	6-16
<b>Vehicle performance configuration .....</b>	<b>6-18</b>
Safety Interlocks .....	6-18
Torque mode/speed mode.....	6-19
Throttle.....	6-20

Driveability Features .....	6-22
Acceleration and braking .....	6-23
Footbrake.....	6-24
Steering inputs – twin driving motor systems .....	6-24
Driveability profiles.....	6-26
Smoothing Output Torque .....	6-28
Preventing Wheel Lock Scenarios.....	6-29
Controlled roll-off .....	6-30
Hill hold .....	6-30
Inching .....	6-30
Belly Switch.....	6-31
Drivability select switches .....	6-31
Economy .....	6-31
Pump configuration.....	6-31
Power steer configuration.....	6-33
<b>Vehicle features and functions.....</b>	<b>6-34</b>
Contactors.....	6-34
Line contactor .....	6-34
Electro-mechanical brake .....	6-34
External LED.....	6-35
Alarm buzzer.....	6-35
Brake Lights .....	6-35
Horn .....	6-35
Vehicle Speed Calculation.....	6-35
Distance Calculation .....	6-36
Service Indication .....	6-36
Traction motor cooling fan .....	6-36
Controller heatsink / motor cooling fan .....	6-37
Motor over-temperature protection .....	6-37
Motor over-speed protection.....	6-37
Battery protection.....	6-37
Displays .....	6-39

---

<b>Reading status variables .....</b>	<b>7-2</b>
Motor measurements .....	7-2
Heatsink temperature .....	7-2
Identification and version .....	7-2
Battery monitoring.....	7-2
Hours counters .....	7-3
<b>Logging .....</b>	<b>7-3</b>
FIFO event logs .....	7-3
Event counters .....	7-4
Operational monitoring .....	7-4
<b>CANopen abort code .....</b>	<b>7-4</b>
<b>Faults and warnings .....</b>	<b>7-6</b>
Introduction .....	7-6
Fault identification .....	7-6
Fault list.....	7-10
<b>Upgrading the controller software .....</b>	<b>7-10</b>





## Chapter 1: Introduction

# About Gen4 documentation

## This version of the manual

This version of the Gen4 manual replaces all previous versions. Sevcon has made every effort to ensure this document is complete and accurate at the time of printing. In accordance with our policy of continuing product improvement, all data in this document is subject to change or correction without prior notice.

## Copyright

This manual is copyrighted 2013 by Sevcon. All rights are reserved. This manual may not be copied in whole or in part, nor transferred to any other media or language, without the express written permission of Sevcon.

## Scope of this manual

The Application Reference Manual provides important information on configuring lift and traction drive systems using Gen4 controllers as well as details on sizing and selecting system components, options and accessories.

The manual also presents important information about the Gen4 product range.

## Related documents

The following documents are available from Sevcon:

- The Object Dictionary providing important information about CANopen communication with Gen4.
- Device Configuration Files (DCF) and Electronic Data Sheets (EDS) for each Gen4 model and revision.

## Drawings and units

Orthographic illustrations in this manual are drawn in Third Angle Projection. SI units are used throughout this manual.

## Dangers, Warnings, Cautions and Notes

Special attention must be paid to the information presented in Dangers, Warnings, Cautions and Notes when they appear in this manual. Examples of the style and purpose of each are shown below:



**A DANGER indicates a hazard with a high level of risk, which if not avoided, will result in death or serious injury.**

---



**A WARNING indicates a hazard with a medium level of risk, which if not avoided, could result in death or serious injury.**

---



**A CAUTION indicates a hazard with a low level of risk, which if not avoided, could result in a minor or moderate injury.**

---



*A NOTE indicates a risk of damage to the process, product or surroundings or other important information that helps you make better use of your Sevcon product.*

---

## Product identification label

If you have a customized product your unique identifier will appear at the end of the Type number. When discussing technical issues with Sevcon always have your product's Type number, Part number and Serial number available. Figure 1 shows a typical product identification label.



Figure 1 Product identification label

## Technical support

For technical queries and application engineering support on this or any other Sevcon product please contact your nearest Sevcon sales office listed on the inside front cover of this manual. Alternatively you can submit enquiries and find the details of the nearest support centre through the Sevcon website, [www.sevcon.com](http://www.sevcon.com).

## Product warranty

Please refer to the terms and conditions of sale or contract under which the Gen4 was purchased for full details of the applicable warranty.



## Chapter 2: About the Gen4

# Introduction

Sevcon Gen4 controllers are designed to control 3-phase AC induction motors and Permanent Magnet AC (PMA) motors in battery powered traction and pump applications. A range of models is available to suit a wide number of applications and cooling regimes.

The controller adapts its output current to suit the loading conditions and the ambient in which it is operating (temporarily shutting down if necessary). It will also protect itself if incorrectly wired.

Signal wiring and power connections have been designed to be as simple and straight forward as possible. Analogue and digital signal inputs and outputs are provided for switches, sensors, contactors, hydraulic valves and CAN communications. These electrical signals can be mapped to Gen4's software functions to suit a wide range of traction and pump applications.



---

*NOTE: Given Gen4's mapping versatility it is important to ensure you map your application signals to the correct software functions (see 'Object mapping' on page 6-11). A common configuration is supplied by default which may suit your needs or act as a starting point for further configuration.*

---

Configuration and control of Gen4 is fully customizable using Sevcon's Calibrator handset or DVT, an intuitive Windows based configuration software tool.

A single green LED is provided to give a visual indication of the state of the controller. This signal can be replicated on a dashboard mounted light for example.

## Standard features and capabilities

### Available options

There are three mechanical package options (Figure 2) for the Gen4 controller at various voltage and current ratings.

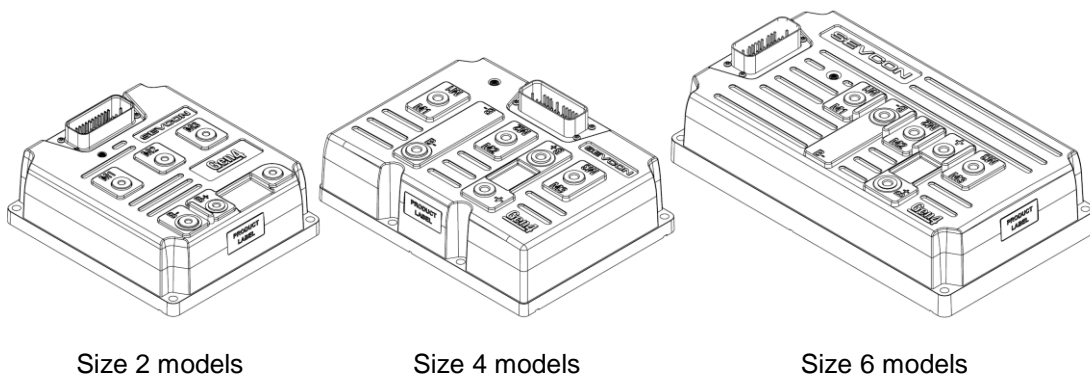

Figure 2 Mechanical package options

## Intended use of the Gen4

The Gen4 motor controller can be used in any of these main applications for both pump and traction control:

- Counterbalanced, warehouse and pedestrian fork lift trucks (Classes 1 to 3, FLT1, 2 & 3)
- Airport ground support (AGS), including tow tractors
- Utility vehicles
- Burden carriers
- Sweepers and scrubbers
- Golf buggies/carts
- Neighbourhood electric vehicles (NEV)
- Scooters
- Marine

## Available accessories

The following accessories are available from Sevcon

- Loose equipment kit (connectors and pins) for Gen4
- CANopen Calibrator Handset
- SmartView™ display
- ClearView™ display
- Hourmeters
- Contactors
- Fuses
- Drive Wizard - PC based configuration tool
- SCWiz – PC based motor characterisation tool

## Overview of a truck drive system

Each traction or pump application requires a number of system components. The main components (excluding control inputs such as throttle and seat switch) are shown in Figure 3. In this example there are two controllers, a traction motor and a hydraulic pump, however all the main components would be the same if controller 2 was also powering a traction motor.

Communication between the controllers is achieved using the CANopen protocol. This protocol also allows Gen4 to communicate with other non-Sevcon, CANopen compliant devices.

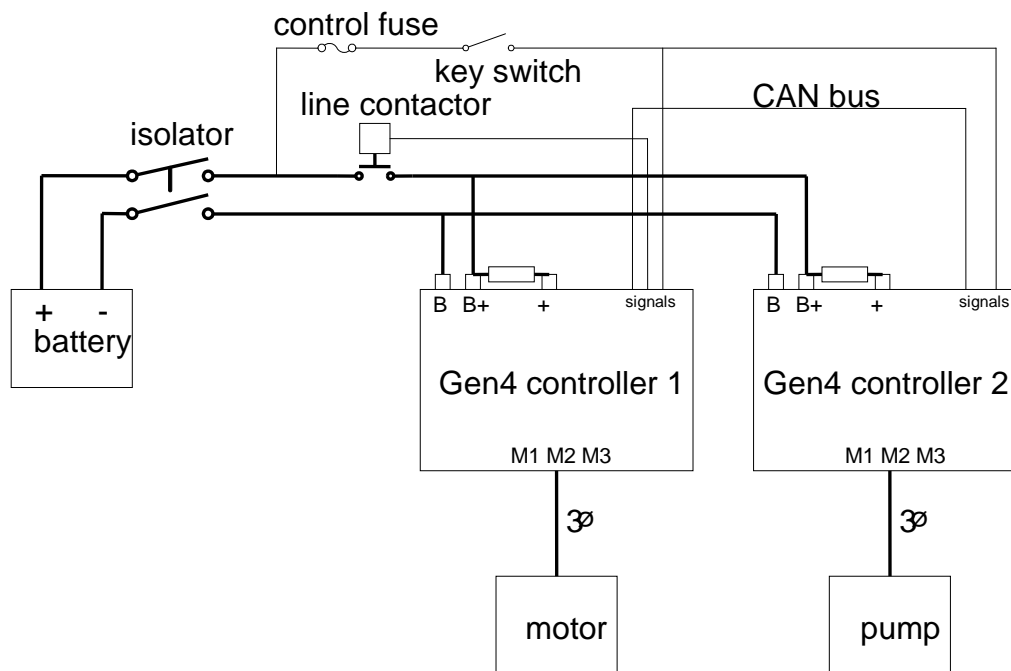

Figure 3 Truck system components

Signal power for the internal control circuits and software is derived from the battery via the control fuse and key switch as shown. No external in-rush current limiting is needed as long as Gen4 is used to control the line contactor and hence the timing of its closure. The software controls the start up sequence in this order:

1. Charge the input capacitors to within a user definable percentage (using 5820<sub>h</sub>) of battery voltage (via the key switch signal line).
2. Close line contactor.
3. Generate output to the motor as demanded.

A line input fuse can be mounted on the body of the controller. The 'B+' terminal is a dummy terminal. If the fuse is mounted elsewhere, connections from the battery positive are made to the controller '+' terminal see "On-board fuse mounting" section.



## Principles of operation

### Functional description

The main function of Gen4 is to control the power to 3-phase squirrel-cage AC induction or PMAC motors in electric vehicles. Four-quadrant control of motor torque and speed (driving and braking torque in the forward and reverse directions) is allowed without the need for directional contactors. Regenerative braking is used to recover kinetic energy which is converted into electrical energy for storage in the battery.

In a traction application control commands are made by the driver using a combination of digital controls (direction, foot switch, seat switch, etc.) and analogue controls (throttle and foot brake). The controller provides all the functions necessary to validate the driver's commands and to profile the demand for speed and torque according to stored parameters.

Throttle inputs can be configured as speed or torque demands with throttle-dependent speed limits: in either case, a torque demand is continually calculated to take account of pre-set limits on the level and rate-of-change of torque. The torque demand is used to calculate current demands; that is, the controller calculates what currents will be required within the motor to generate the required torque.

There are two distinct components of the current, known as the d-q axis currents, which control current flow in the motor. The d-axis current is responsible for producing magnetic flux, but does not by itself produce torque. The q-axis current represents the torque-producing current.



---

*NOTE: When a vehicle is ready to drive, but no torque is being demanded by the driver, the d-axis or magnetizing current will be present in the motor so that the vehicle will respond immediately to a torque demand. To save energy the magnetizing current is removed if the vehicle is stationary and no torque has been demanded after a set period.*

---

Measured phase currents and current demands  $i_d$  and  $i_q$ , the d-q axis currents, are used as part of a closed-loop control system to calculate the necessary voltage demands for each phase of the motor. Voltage demands are then turned into PWM demands for each phase using the Space Vector Modulation (SVM) technique. SVM ensures optimum use of the power semiconductors.

### Power conversion section

The power conversion section of Gen4 employs a 6-switch MOSFET bridge operating at an effective frequency of either 16 kHz or 24kHz ( equates to a PWM switching frequency of 8kHz or 12kHz and is set via object 5830<sub>n</sub>). Excellent electrical and thermal efficiency is achieved by:

- Minimization of thermal resistances.
- Use of the latest MOSFET technology
- Internal thermal protection (if temperatures are excessive, output torque is reduced).
- Overcurrent protection using device characteristics.
- Internal measurement of output current.
- Overvoltage trip in the event of regenerative braking raising battery voltage to unsafe levels.

## Dual traction motor

In the case of dual traction motors, there is additional processing of the associated steering signal (from a potentiometer or switches) in order to generate separate torque demands for the left and right motors of the vehicle. This allows the two motors to be operated at different speeds, which greatly assists in turning the vehicle and prevents wheel scrub. After the torque demands have been generated, the operation of each motor control system is as described in the case of a single traction motor.

## Pump motors

Pump motor control is similar to traction motor control, although motion is requested using a different combination of switches.

## Interfaces

In addition to its motor control functions, Gen4 offers many other functions designed to interface with electric vehicles. A variety of digital and analogue input sources are supported, as listed in 'Signal connections' on page 3-14.

Voltage and current control of up to three contactors or proportional valves is provided by Gen4, and includes built-in freewheeling diodes for spike suppression. All I/O on the Gen4 controller is protected against short-circuit to the battery positive and negative terminals.

Connectivity and interoperability with other system devices (for example another Gen4 controller) using a CANbus and the CANopen protocol is provided. In addition to in-service operation, the CANopen protocol allows the controller to be commissioned using the Calibrator handset or Sevcon's DVT tool. In addition Sevcon's SCWiz PC based tool provides the function to self-characterize most induction motors and hence simplify the process of putting a new motor into service.

For simple visual diagnosis of system faults and to monitor system status, a green LED is provided on the body of the controller. It is continuously lit when there is no fault but flashes a different number of times, in a repeated pattern, when there is a fault. The number of flashes indicates the type of fault (see " on page 1).

## Master-slave operation

The Gen4 controller contains both master and slave functions as shown in Figure 4. They operate as follows:

- **Slave function:** implements the CANopen Generic I/O Profile (DS401) and the Drives and Motion Control Profile (DSP402).
- **Master function:** implements vehicle functionality (traction and pump control) and CANopen network management.

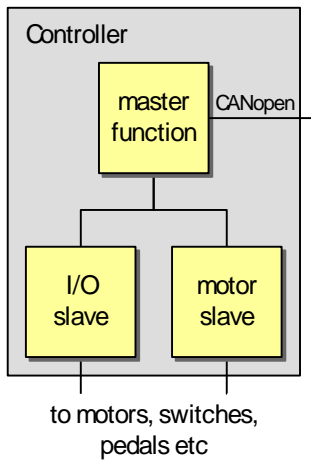

Figure 4 Single controller

## Torque mode

In this mode Gen4 maintains the motor torque output at a constant value for a given throttle position. This is similar to DC motors (in particular, series wound DC motors) and provides a driving experience like a car. To prevent excessive speed when the load torque is low, for example when driving down hill, a maximum vehicle speed can be set.

## Speed mode



**WARNING: Speed mode (or speed control) is not recommended for on-highway vehicles as it can cause the traction motor/wheel to remain locked or brake severely if the wheel is momentarily locked due to loss of traction on a slippery surface and/or mechanical braking.**

In this mode Gen4 maintains the motor at a constant speed for a given throttle position as long as sufficient torque is available. Speed mode differs from torque mode in that the torque value applied to the motor is calculated by the controller based on the operator's requested speed (determined by throttle position) and the vehicle's actual speed. This mode is useful where accurate speed control is required irrespective of the motor torque.

# Safety and protective functions

## General



---

**WARNING:** Electric vehicles can be dangerous. All testing, fault-finding and adjustment should be done only by competent personnel. The drive wheels should always be off the floor and free to rotate during the following procedures. The vehicle manufacturer's manual should always be consulted before any operation is attempted.

---



---

**WARNING:** The battery must be disconnected before replacing the controller. After the battery has been disconnected, wait 30 seconds for the internal capacitors to discharge before handling the controller.

---



---

**WARNING:** Battery vent caps must be securely in place before connecting the controller to a battery as an arc may occur due to the controller's internal capacitance when it is first connected.

---



---

**WARNING:** If a PMAC motor is being used at the maximum motor speed the peak line to line back emf must not exceed the non-operational voltage limit specified in (add ref to section 4 input voltage table). The controller may be damaged if the back emf exceeds this level.

---



---

**WARNING:** Do not tow vehicles that have PMAC motors, the motors act as generators and may cause high currents to flow in the motor, controller or battery system. If towed at a speed in excess of the vehicle rated speed the voltage generated by the motor may damage the controller or battery.

---



---

**WARNING:** When a PMAC motor is acting as a generator, for example when braking or driving down hill, the short circuit current must not exceed the controller current rating. The short circuit current should be calculated for all vehicle speeds and must be less than the controller current rating. If the current is greater than the controller current rating then measures must be taken to protect the controller from the motor acting as a generator. Possible measures include adding a disconnect switch between the motor and controller on at least 2 out of the 3 phases, or adding fuses in each phase. Contact your local Sevcon representative for further information and guidance.

---



---

**CAUTION:** Ensure that contactors with blow-out magnets are wired with the correct polarity to their power terminals as indicated by the + sign on the top moulding.

---



---

NOTE: Do not attempt to open the controller as there are no serviceable components. Opening the controller will invalidate the warranty.

---



---

NOTE: Do not mechanically modify the controller in any way as unexpected damage may occur. Mechanically modifying the controller will invalidate the warranty.

---



---

NOTE: Use cables of the appropriate rating and fuse them according to the applicable national vehicle and electrical codes.

---



---

NOTE: Do not use any other form of fasteners other than those supplied with the controller without contacting Sevcon for advice. Use of inappropriate fasteners or torques could damage the controller.

---



---

NOTE: Where appropriate use of a suitable line contactor should be considered.

---



---

CAUTION: Electric vehicles are subject to national and international standards of construction and operation which must be observed. It is the responsibility of the vehicle manufacturer to identify the correct standards and ensure that it's vehicle meets these standards. As a major electrical control component, the role of the Gen4 motor controller should be carefully considered and relevant safety precautions taken. The Gen4 has several features which can be configured to help the system integrator to meet vehicle safety standards. Sevcon accepts no responsibility for incorrect application of its products.

---

## On-Highway Vehicles

### General

This applies to all on-highway vehicles, such as motorcycles and cars.

The installer must ensure an appropriate controller configuration is set to ensure that the vehicle remains in a safe condition, even in the event of a fault.

### Inputs

Always ensure drive inputs have adequate protection. Inputs such as the throttle should have appropriate wire-off detection configured. Single point failures should never cause an unsafe condition.

Gen4 supports wire-off detection on all analogue inputs, and it contains various safety interlocks to prevent unexpected drive due to a wiring fault (e.g. FS1 switch, dual throttle inputs).

Sevcon recommends that the following features are enabled for all applications:

- Wire-off detection on analogue inputs, particularly the throttle.
- A valid analogue input voltage which is more than 0.5V from wire off limits
- Appropriate safety interlocks to ensure a single point of failure cannot cause an unsafe driving condition.

Refer to sections Analogue inputs (page 6-14) and Vehicle performance configuration (page 6-18) for more information.

### Notes on Features

The Gen4 is a generic motor controller intended for use in both highway AND non-highway industrial applications. Not all of the controller features are suitable for an on-highway vehicle. Some features, if activated, could lead to the controller forcing a motor condition that is not directly requested by the throttle, such as undesired drive or harsher than expected braking.

Sevcon recommends that the following features are DISABLED for any on-highway applications:

- Proportional Speed Limit<sup>1</sup>.
- Hill Hold<sup>1</sup>.
- Controlled Roll-Off<sup>1</sup>.
- Speed mode (or speed control)<sup>1</sup>.
- Electromechanical Brake output<sup>1</sup>.
- Inching<sup>2</sup>.
- Belly switch<sup>2</sup>.
- Unused Driveability Profiles<sup>3</sup>.

## NOTES:

1. These features can cause the traction motor/wheel to remain locked or brake severely if the wheel is momentarily locked due to loss of traction on a slippery surface and/or mechanical braking.
2. These features can cause unexpected drive if accidentally activated.
3. This feature can cause a sudden reduction in maximum speed if a driveability profile is accidentally activated and is incorrectly configured.

In addition, the following features must be configured correctly

- Steering map, if used to reduce maximum outer wheel speed with steering angle.

## Fault detection and handling

There are five categories of faults as described in Table 1. For a detailed list of faults see Table 7 on page 7-10.

Fault severity	Controller latched off until	Consequences
Return to base (RTB)	Cleared by Sevcon personnel	Immediate shut down of the system with the exception of the power steering if needed. Power is removed to nearly all external components.
Very severe (VS)	Cleared by authorized service personnel	Immediate shut down of the system with the exception of the power steering if needed. Power is removed to nearly all external components.
Severe (S)	Keyswitch recycled (turned off then on)	Immediate shut down of the system with the exception of the power steering if needed. Power is removed to nearly all external components.
Drive-inhibit (DI)	User deselects all drive switches before reselecting	Neutral brakes or coasts the traction motor(s) to a stop. The fault prevents the operator initiating drive, but does not inhibit braking function, in particular, controlled roll-off braking.
Information (I)	Not latched	Information faults do not require immediate action, although some cutback of power or speed may occur.

Table 1 Fault categories





## Chapter 3: Installation

# Mounting Gen4

## Location

The mounting location for the controller should be chosen with care taking into account the following considerations:-

- Do not mount the controller on the outside of a vehicle where it would be assessable to unauthorized personnel (for the purposes of UL, the controller enclosure is not considered to be the 'ultimate enclosure' and should be sited within another enclosure).
- Do not mount the controller where it may be susceptible to damage due to minor collisions, impact from road debris or chemical contamination (see 'Protection from chemical contamination' below).
- Although the controller has a high degree of ingress protection the electrical power terminals do not. Avoid mounting the controller in locations where it may be submerged in water or subjected to long term exposure to jets of water or exposed to potentially conductive contamination and or debris.
- Take note of the thermal and EMC considerations as explained later in this section of the manual.

## Protection from chemical contamination

The Polycarbonate cover of Gen4 controllers are designed for good all-round protection of the electronics. However the controller should be sited so it cannot come into contact with significant quantities of industrial chemicals. The following have shown to be damaging to the cover:-

- Most esters (contained in some 'bio' hydraulic fluid such as Shell Naturelle HF-E)
- Most industrial alcohols (contained in some contact grease such as Electrolube CG53A)



**Electrical terminals on the controller present an electric shock hazard. High currents can also present a burn hazard. You must ensure that the electrical terminals of the controller are protected against access by unauthorized personnel.**

---

## Orientation

The controller can be mounted in any orientation.

## Clearance for LED access

If you want an operator of your vehicle to be able to view the onboard LED, it is advisable to consider the line of sight to the LED at this time.

## Mounting hole pattern

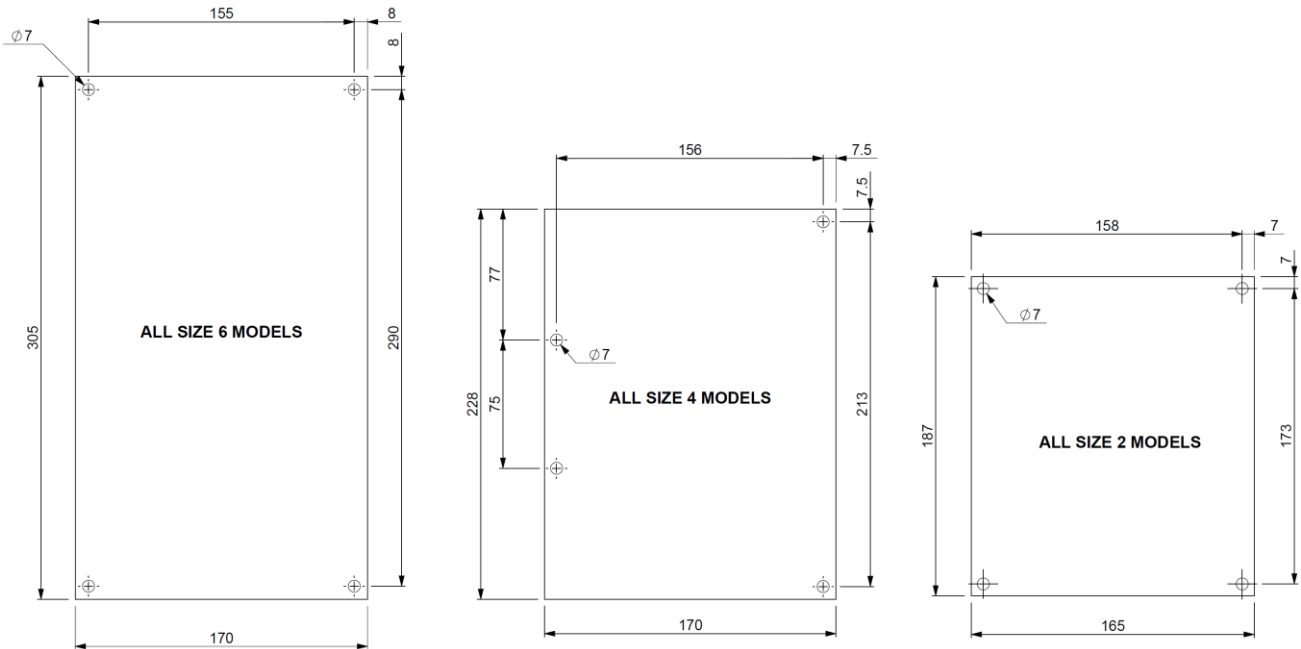

Minimum flatness of mounting surfaces: 0.2mm



Failure to comply with this flatness specification can cause deformation and damage to the product.

## Equipment required:

- 4 x M6 socket cap head bolts, nuts and spring washers. Bolts need to be long enough to pass through 12 or 20 mm of Gen4 base plate (depending on controller type) and your mounting surface thickness.
- T hand-socket wrench or Allen key
- Thermal grease

Recommended torque setting: 10 Nm  $\pm$  2 Nm

## Thermal grease application

It is recommended that a thermal interface material or thermal paste is used between controller and mounting face. Spread a layer of thermal grease (such as Dow Corning 340) as described below, before bolting to your mounting surface.

- Thermal compound should be applied with a small soft paint roller to ensure an even spread of thermal compound.
- The most appropriate thickness will look white but with a greyish colour still showing through from the controller base or vehicle mounting face material. *It should be noted that too little thermal compound will not fill all gaps left the flatness mismatch of the contact surfaces, but too much thermal compound may prevent the gap from closing up when tightening.*
- It is recommended that thermal compound is applied to both the Controller base and the vehicle/panel/boost plate surfaces.

- The controller should then be placed onto the vehicle/panel/heatsink.
- It is important that the two surfaces are then rubbed together in order to help transfer the thermal compound between the two surface.
- The entire assembly is then bolted together at all mounting holes.

An example of a good thermal compound spreading can be seen in the photo below:-

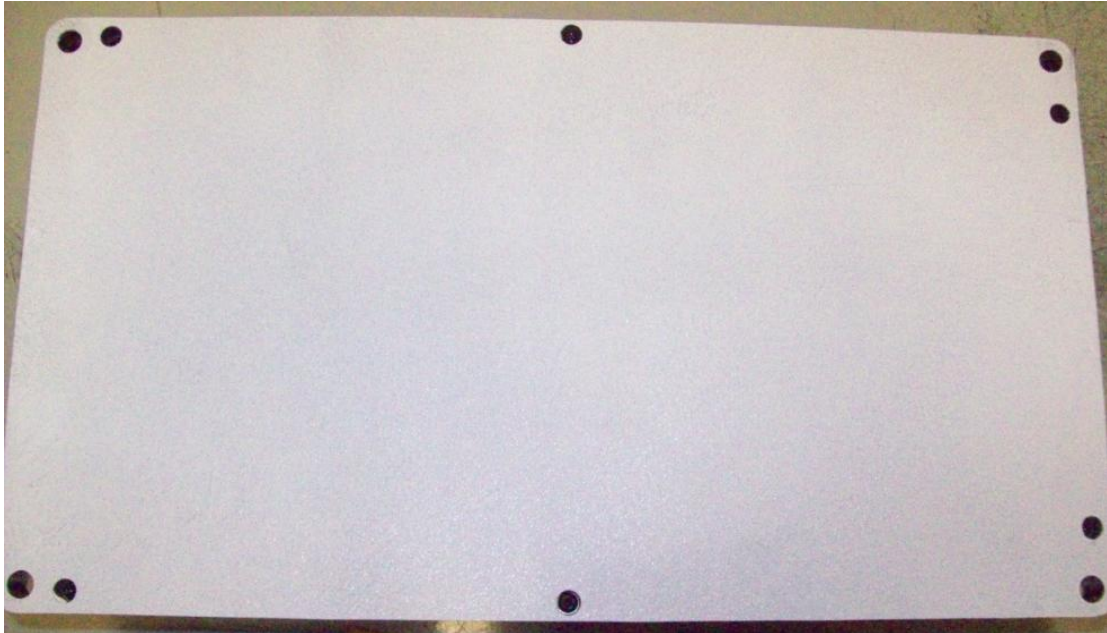

How effective the spreading technique is can be checked by removing the controller and inspecting the paste residue left on the mounting faces. On a well applied paste application, the controller will be difficult to remove and a rippled surface will be left on the paste surface as shown (magnified) below:-



## Cooling requirements

To ensure you get the maximum performance from your Gen4 controller:

- Keep it away from other heat generating devices on the vehicle
- Maintain its ambient operating temperature below the specified maximum (see 'Operating environment' on page 4-8)

To obtain maximum performance it is important to keep Gen4's base plate within the operating temperature range. To do this, mount Gen4 to a surface capable of conducting away the waste heat. Finned heatsinks are considerably better at doing this than flat plates. For example, a finned heatsink used at Sevcon has a footprint of 330mm x 200mm and thermal resistance of 0.3°C/W, whereas a plate approximately 420 mm x 270 mm x 9.5 mm will give approximately the same thermal performance (0.3°C/W). Ratings achievable with conductive heatsinking are shown in Figure 10 on page 4-4.

In Sevcon's experience the thermal resistance of the stand-alone Gen4 packages and achievable thermal resistances to ambient using conductive heatsinking are as shown in the table below. These are given as a guide: actual performance in an application must be verified.

Gen4 Size	Thermal resistance without additional heatsinking (°C/W)	Thermal resistance achievable with finned heatsink (°C/W)	Dimension of finned heatsink (W x L)
Size 2	0.7	0.5	250mm x 180mm
Size 4	0.6	0.3	330mm x 200mm
Size 6	0.5	0.2	330mm x 280mm

Cooling performance is affected by mounting surface flatness and the thermal transfer between mounting surface and Gen4. Ensure your application of thermal grease is effective and your mounting surface meets the flatness figures as described in the 'Mounting' section above.

## EMC guidelines

The following guidelines are intended to help vehicle manufacturers to meet the requirements for Electromagnetic Compatibility. Any high speed switch is capable of generating harmonics at frequencies that are many multiples of its basic operating frequency. It is the objective of a good installation to minimise, contain or absorb the resultant emissions. All wiring is capable of acting as a receiving or transmitting antenna. Arrange wiring to take maximum advantage of the structural metal work inherent in most vehicles. Link vehicle metalwork with conductive braids.



---

CAUTION: It is the responsibility of the vehicle manufacturer to ensure compliance of the vehicle to all applicable EMC standards.

---

## General measures

### Power cables

Route all cable within the vehicle framework and keep as low in the structure as is practical - a cable run within a main chassis member is better screened from the environment than one routed through or adjacent to an overhead guard. Keep cables short to minimize emitting and receiving surfaces. Shielding by the structure may not always be sufficient - cables run through metal shrouds may be required to contain emissions.

Parallel runs of cables in common circuits can serve to cancel emissions - the battery positive and negative cables following similar paths is an example. Tie all cables into a fixed layout and do not deviate from the approved layout in production vehicles. A re-routed battery cable could negate any approvals obtained.

Keep power cables at least 300mm from signal cables.

### Signal cables

Keep all wiring harnesses short and route wiring close to vehicle metalwork. Keep all signal wires clear of power cables and consider the use of screened cable. Keep control wiring clear of power cables when it carries analogue information - for example, accelerator wiring. Tie all wiring securely and ensure it always follows the same layout.

### Controller

Thermal and EMC requirements tend to be in opposition. Additional insulation between the controller assembly and the vehicle frame work reduces capacitive coupling and hence emissions but tends to reduce thermal ratings. Establish a working balance by experiment. Document the complete installation, in detail, and faithfully reproduce on it all production vehicles. Before making changes, consider the effect on EMC compliance. A simple cost reduction change could have a significant negative effect on the EMC compliance of a vehicle.

## Measures required for specific signals

### Battery power cables

Cables should be as short as possible. Minimise the loop area of the B+ and B- wiring. A common mode ferrite choke may be required.

### Motor power cables

Cables should be as short as possible. Minimise the loop area of the M1 M2 M3 wiring. A common mode ferrite choke may be required

### Motor encoder connection

The encoder cable must be as short as possible. A multi-core screened cable should be used. The inner cores should be used for the encoder supply and encoder ground and the AB or UVW signals. The cable screen should be connected to the B- terminal. Ensure that the screen does not connect the motor chassis back to the B- terminal to avoid motor power cable current returning through the encoder cable screen.

### CAN bus

A multi-core screened cable should be used. The inner cores must be twisted pairs. One twisted pair should be used for CANH and CANL. The other twisted pair should be used for CAN supply. Ensure that there is a common ground connection for all nodes on the CAN bus. If there is a node on the bus which is galvanically isolated from the Gen4 controller then the CAN ground on this node must be connected to the Gen4 controller B-. The cable screen should be connected to the B- terminal at the Gen4 controller

### Keyswitch

The keywire should be as short as possible. Minimise the loop area of the loop formed by the traction battery, keyswitch, keyswitch supply on the Gen4, and the B- return wire to the battery. Do not connect additional battery loads to the keyswitch wire.

### Contactors drivers

Minimise the loop area formed by the contactor driver output and the contactor supply +. Use of twisted pair will reduce emissions. Use of screened cable with the screen connected to B- will further reduce emissions.

### Throttle input

The throttle input is referenced to the controller B- connection, it is therefore very important that the throttle ground connection goes directly to the B- terminal on the controller. Ensure that there is no common ground path for the throttle with the battery power connection or any other power or switching loads on the vehicle. Screened cable for the throttle supply and wiper may be required for higher levels of immunity, the screen should be connected to B-.

## Additional measures

Where it has not been possible to meet the required EMC specifications using the standard measures listed above it may be necessary to use one or more of the following measures:-

- Use of screened cable for all control connections
- Use of a Faraday cage around the controller and motor

- Addition of an LC filter on the keyswitch supply
- Battery cable should be screened with the screen connected to the battery chassis and controller chassis.
- Motor cable should be screened with the screen connected to the motor chassis and controller chassis.
- A common mode ferrite choke for all the small signal connections will attenuate common mode emissions

## Problems to avoid



EMC is a complex subject and on a typical vehicle there are many potential radiators and receivers. Measures taken on a vehicle to improve EMC can unintentionally make the situation worse.

---

- Beware of devices that are connected to the small signal wiring which have a significant (>10nF) capacitance to vehicle chassis. The capacitance to vehicle chassis can cause currents to flow out of the Gen4 controller along the signal wiring to the device and back to the controller via the vehicle chassis.
- When using screened cable beware of generating ground loops in which currents may be induced or which may cause noise currents to flow via unintended paths.



## Connecting power cables

See also 'EMC guidelines' on page 3-6.

### Battery and motor connections

---



CAUTION: Cables carrying high AC currents are subject to alternating forces and may require support in the cable harness to avoid long-term fatigue.

---

Equipment required for **size 4 or 6 models**:

- Cables sized to suit the controller and application (see table below)
- M8 crimp ring lugs
- Crimp tool
- Suitable torque wrench and socket

Torque setting: 11 Nm  $\pm$  2 Nm

Equipment required for **size 2 models**:

- Cables sized to suit the controller and application (see table below)
- M6 crimp ring lugs
- Crimp tool
- Suitable torque wrench and socket

Torque setting: 7 Nm  $\pm$  1 Nm

Consider cable routing before making connections.

- Keep cable runs short
- Minimize current loops by keeping positive and negative cables as close together as possible.
- Route cables away from the LED if you intend to make this visible under normal operating conditions.

Connect your power cables using the bolts supplied. **USE THE CORRECT TORQUE.** They are sized to clamp one ring lug thickness. Use a longer bolt if you are fastening more than one ring lug. You need thread engagement of at least 10 mm and the maximum penetration is 15 mm.



CAUTION: If you use a bolt which is too long, damage to the terminal and overheating of the connection may occur. If you use a bolt which is too short and there isn't enough thread engagement you may damage the threads.

---



CAUTION: 'Bottoming out' a screw in the terminal marked 'B+' will damage the cover leading to liquid ingress

---

## Cable sizes

---



CAUTION: When deciding on power cable diameter, consideration must be given to cable length, grouping of cables, the maximum allowable temperature rise and the temperature rating of the chosen cable.

---

The following table gives guidance on the cable size needed for various currents in welding cable, not grouped with other cables, in 25°C ambient with 60°C temperature rise on the cable surface.

Gen4 average (rms) current	Cable sizes	
	metric	US (approx equivalent)
180 A	25 mm <sup>2</sup>	4 AWG
225 A	35 mm <sup>2</sup>	2 AWG
280 A	50 mm <sup>2</sup>	1 AWG
350 A	70 mm <sup>2</sup>	2/0 AWG

## On-board fuse mounting

You can mount your main input protection fuse directly onto the controller body as shown below . Select the appropriate fuse from the table below. Connect the battery positive cable to the B+ terminal. Connecting to the end marked '+' (or un-named in the case of size 2) will leave your installation without a fuse unless located elsewhere in the system. The B+ terminal is a dummy terminal to allow fuse connection only and has no internal connection.

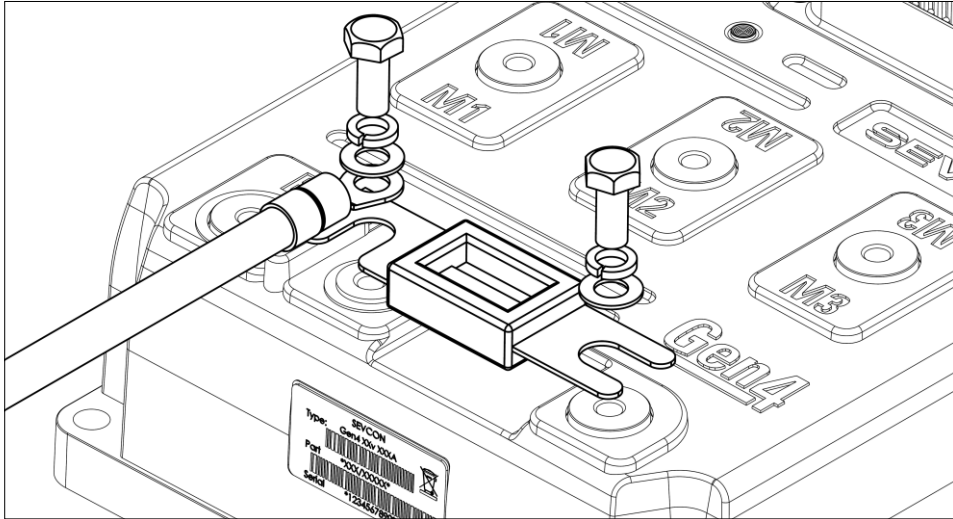

Figure 5 On-board fuse mounting – size 2 models

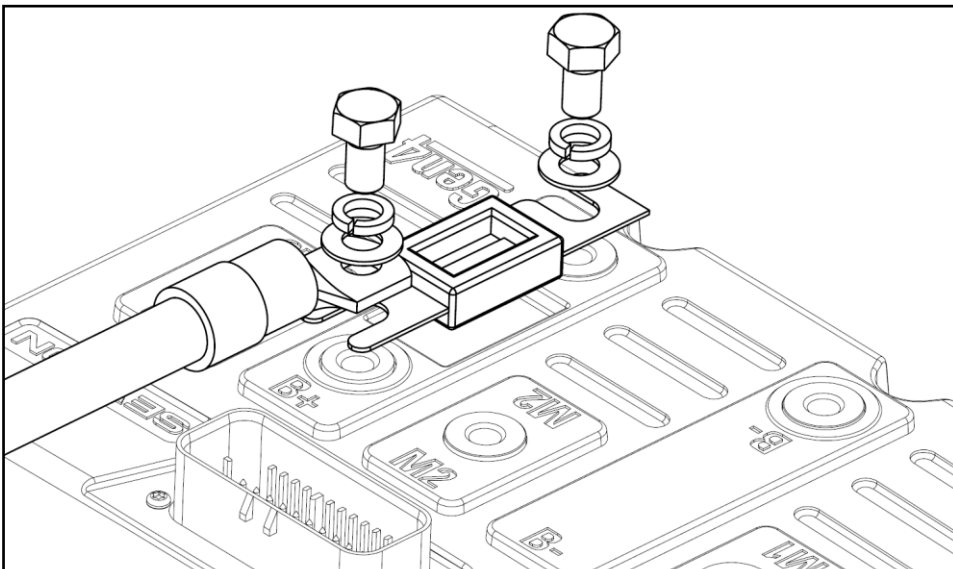

Figure 6 On-board fuse mounting – size 4 models

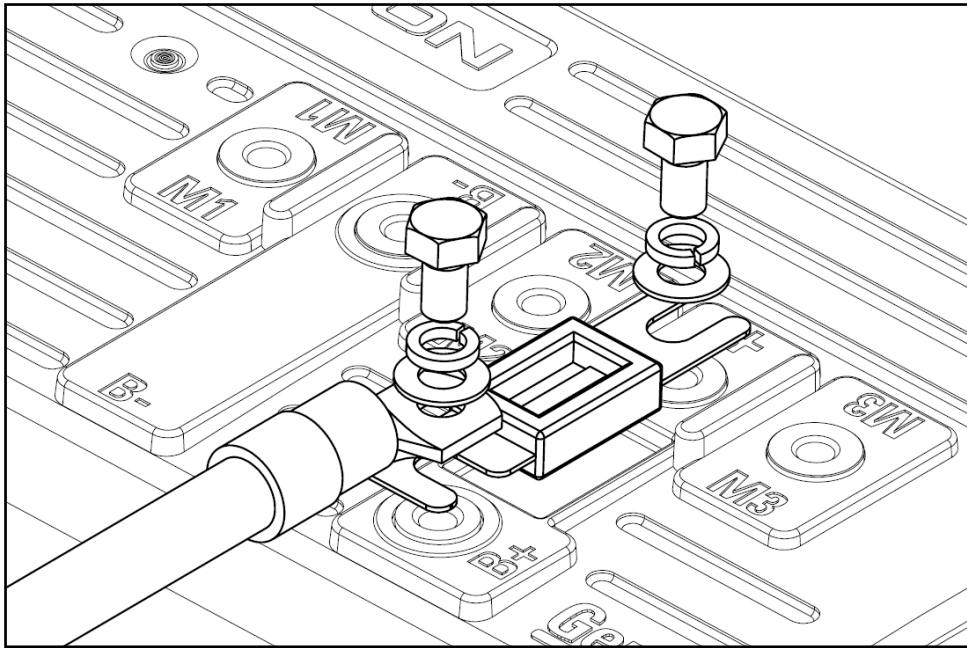

Figure 7 On-board fuse mounting – size 6 models

## Fuse rating and selection

On-board fuse dimensions are in accordance with DIN43560/1

Gen4 input voltage	Gen4 peak output current	Fuse rating	Sevcon part number
24V/36 V	300 A	325 A	858/32044
	450 A	425 A	858/81990
	650 A	750 A	858/33021
36V/48 V	275 A	250 A	858/29043
	450 A	425 A	858/81990
	650 A	750 A	858/33021
72V/80 V	180 A	200 A	858/83339
	350 A	355 A	858/32045
	550 A	500 A	858/32043
96V/110V	300A	355A	858/32045

## Signal wiring

Assemble your wiring harness using wire of the sizes recommended below and the Sevcon loose connector kit (P/N 661/27091). The use of twisted pair and in some cases twisted-screened cables is recommended for the speed sensor and CANbus wiring.

To make a connection, gently push the connector housing onto the appropriate mating half on the Gen4. Never force a connector. Connectors are keyed to prevent incorrect insertion.

Twisted, shielded wire is recommended. Keep signals away from power cables to avoid interference. See also 'EMC guidelines' on page 3-6.

## Signal wire sizes

Use wire between 0.5 mm<sup>2</sup> (20 AWG) and 1.5 mm<sup>2</sup> (16 AWG) for all signal wiring. Single twisted pair cable is readily available in 0.5 mm<sup>2</sup> (20 AWG).

## CANbus termination

See also 'EMC guidelines' on page 3-6.

If your system has more than one CAN node, connect the nodes in a 'daisy chain' arrangement (Figure 8) and terminate the connections of the two end nodes with a 120  $\Omega$  resistor. If the end node is a Gen4, link pins 2 and 24 on the customer connector, a 120  $\Omega$  resistor is built into the controller. If you have a single node system the termination resistor should be connected so that the bus operates correctly when configuration tools are used.

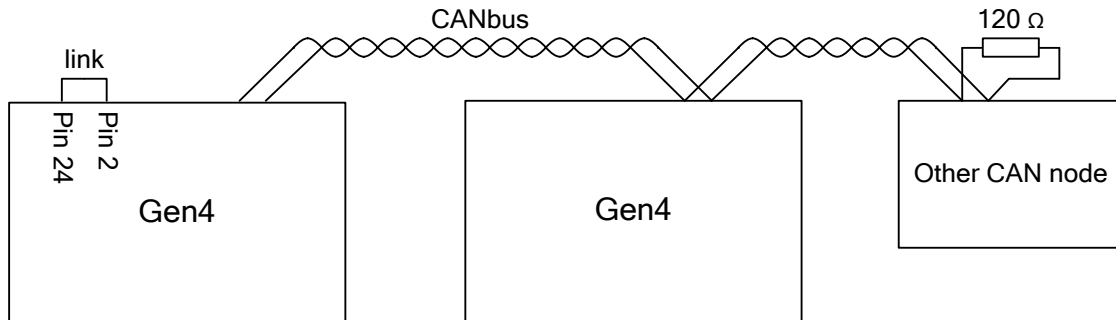

Figure 8 CAN node termination

## Signal connections



**CAUTION:** Do not use contactors which have built in 'economiser' circuits, the internal circuits are not compatible with the controller and may cause malfunction or damage. The same power reduction can be achieved with a standard coil by using the configurable pull-in and hold voltage settings.

Signal connections are made to Gen4 via a 35 way AMPSeal connector.

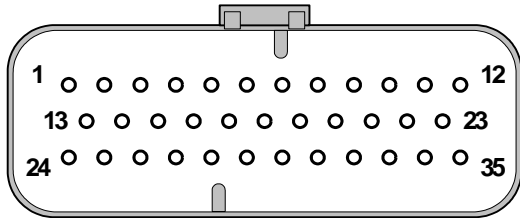

Figure 9 Customer Connector

Pins are protected against short-circuits to the battery positive or negative terminals.



**NOTE:** Please see Tyco Application Specification 114-16016 and Instruction sheet 408-3229 before assembling the AMPSeal connector.

Inserting contacts into connector housing pierces the sealing diaphragm to make the seal to the wire. To maintain IP rating, unused positions must be sealed with appropriate hardware (available from Tyco) if a contact is inserted and then subsequently removed. It is recommended that Tyco strain relief 776463-1 is used (especially for applications where the connector is less than fully populated) to reduce change of ingress through connector body.

Pin	Name	Type	What to connect	Maximum rating	Comment
1	Key switch in	Power	From 'dead' side of key switch via suitable fuse	7A (Total of all contactor output currents plus 1.0A)	This input supplies power from the battery for all the logic circuits. The unit cannot operate without "Key switch in" supply. Pins 1 and 6 (and 10 on Size 4 & 6 models) are connected together internally and can be used individually or in parallel.
2	CAN termination	Comms	To terminate a Gen4 CAN node link pin 2 to pin 24. This connects a 120Ω termination resistor, mounted inside the controller, across the CANbus.		Make the connection only if the Gen4 is physically at the end of the CANbus network (see 'CANbus termination' on page 3-13).

# Installation

Pin	Name	Type	What to connect	Maximum rating	Comment
3	Contactor out 1	Out	To the switched low side of contactor or valve coil. Contactor out 1 usually drives the line contactor. (DO NOT USE WITH CAPACITIVE LOADS).	2.0A per output, subject to a limit of 6A for the total of all the outputs. $V = V_b$	This output provides low side voltage or current control to the load depending on configuration. The output goes low or is chopped to activate the load. It goes high (to $V_b$ ) to de-activate the load.
4	Output 1 Supply +	Power	To one end (high side) of a contactor to be controlled by Contactor out 1	2A	This output feeds power to the contactors. The output is at battery voltage.
5	Encoder "U"	Digital pulse	Position encoder	10V	Use in conjunction with "V" and "W" for PMAC motors.
6	Key-switch in	Power	From 'dead' side of key switch via suitable fuse	7A (Total of all contactor output currents plus 1.0A)	This input supplies power from the battery for all the logic circuits. The unit cannot operate without "Key switch in" supply. Pins 1 and 6 (and 10 on Size 4 & 6 models) are connected together internally and can be used individually or in parallel.
7	Contactor out 2	Out	To the switched low side of contactor or valve coil. (DO NOT USE WITH CAPACITIVE LOADS).	2.0A per output, subject to a limit of 6A for the total of all the outputs. $V = V_b$	This output provides low side voltage or current control to the load depending on configuration. The output goes low or is chopped to activate the load. It goes high (to $V_b$ ) to de-activate the load.
8	Output 2 Supply +	Power	To one end (high side) of a contactor to be controlled by Contactor out 2	2A	This output feeds power to the contactors. The output is at battery voltage.
9	Digital Input 6	Digital	From digital switch input 6.	Type B $V = V_b$ See Table 3	See note to Table 3

Pin	Name	Type	What to connect	Maximum rating	Comment
10	Size 2 (and later size 4) models: 5V supply output	Power	5V supply output	I = 100mA. V = 5V	This output can be used to power transducers or similar devices at 5V and up to 100mA.
	Size 4 & 6 models: Key switch input	Power	From 'dead' side of key switch via suitable fuse	7A (Total of all contactor output currents plus 1.0A)	This input supplies power from the battery for all the logic circuits. The unit cannot operate without "Key switch in" supply. Pins 1, 6 and 10 are connected together internally and can be used individually or in parallel.
11	Contactor out 3	Out	To the switched low side of contactor or valve coil. (DO NOT USE WITH CAPACITIVE LOADS).	2.0A per output, subject to a limit of 6A for the total of all the outputs. V = Vb	This output provides low side voltage or current control to the load depending on configuration. The output goes low or is chopped to activate the load. It goes high (to Vb) to de-activate the load.
12	Output 3 Supply +	Power	To one end (high side) of a contactor to be controlled by Contactor out 3	2A	This output feeds power to the contactors. The output is at battery voltage.
13	CAN High	Comms	CANbus High signal	V = 5 V	Maximum bus speed 1 Mbits/sec Alternative connection to pin 16
14	Encoder A Input	Digital pulse	From the speed encoder A channel	I = 25 mA (internally limited) V = 8 V (for current-source encoders) V = 2.5V or 5V (for open-collector encoders)	Check the speed encoder signals have the correct number of pulses per revolution. Check Gen4 is configured for the type of encoder you are using (open-collector or current-source)



# Installation

Pin	Name	Type	What to connect	Maximum rating	Comment
15	Encoder power supply -	Power	To the negative supply input (0 V) of the speed encoder	I = 100 mA V = 0.5 V	We recommend the use of screened cable for the encoder wiring. Connect the screen to this pin only along with the negative supply.
16	CAN High	Comms	CANbus High signal	V = 5 V	Maximum bus speed 1 Mbits/s. Alternative connection to pin 13
17	Encoder "V"	Digital pulse	Position encoder	10V	Use in conjunction with "U" and "W" for PMAC motors.
18	Digital Input 1	Digital	From digital switch input 1. In a basic configuration this is usually the forward switch.	Type A V = Vb See Table 3	See note to Table 3
19	Digital Input 3	Digital	From digital switch input 3. In a basic configuration this is usually the foot switch (FS1).	Type A V = Vb See Table 3	See note to Table 3
20	Digital Input 5	Digital	From digital switch input 5.	Type B V = Vb See Table 3	See note to Table 3
21	Digital Input 8	Digital	From digital switch input 8.	Type B V = Vb See Table 3	See note to Table 3. Alternative: Sin input from Sin-Cos analogue encoder, only if specified in h/w build
22	Pot. 1 wiper in	Analogu e	From potentiometer 1 wiper.	V = 9.5 V Zin = 82 kΩ (24V/36V and 36V/48V models) Zin = 100 kΩ (24V/36V and 36V/48V models)	Suitable for potentiometers in the range 500 Ω to 10 kΩ, or voltage-output device (e.g. Sevcon linear accelerator) 0 to 5 V or 0 to 10 V. Ensure that at least 0.5V margin exists between the maximum valid throttle and the wire-off threshold

Pin	Name	Type	What to connect	Maximum rating	Comment
23	Pot. 2 wiper in	Analogue	From potentiometer 2 wiper.	V = 9.5 V Z <sub>in</sub> = 82 kΩ (24V/36V and 36V/48V models) Z <sub>in</sub> = 100 kΩ (24V/36V and 36V/48V models)	Suitable for potentiometers in the range 500 Ω to 10 kΩ, or voltage-output device (e.g. Sevcon linear accelerator) 0 to 5 V or 0 to 10 V. Ensure that at least 0.5V margin exists between the maximum valid throttle and the wire-off threshold
24	CAN Low	Comms	CANbus Low signal	V = 5 V	Maximum bus speed 1 Mbits/s. Alternative connection to pin 27
25	Encoder B Input	Digital pulse	From the speed encoder B channel	I = 25 mA (internally limited) V = 8 V (for current-source encoders) V = 2.5V or 5V (for open-collector encoders)	
26	Encoder power supply +	Power	To the positive supply input of the speed encoder	I = 100 mA V = 5V or 10V software selectable	Check the speed encoder you use is compatible with Gen4. See page 6-14 for configuration details.
27	CAN Low	Comms	CANbus Low signal	V = 5 V	Maximum bus speed 1 Mbits/s. Alternative connection to pin 24
28	CAN power supply +	Power	To CAN device requiring external supply	V = 24 V I = 100 mA	Check that the CAN device power supply requirement is suitable for Gen4.
29	Encoder "W"	Digital pulse	Position encoder	10V	Use in conjunction with "U" and "V" for PMAC motors.
30	Digital Input 2	Digital	From digital switch input 2. In a basic configuration this is usually the reverse switch.	Type A V = V <sub>b</sub> See Table 3	See note to Table 3

# Installation

Pin	Name	Type	What to connect	Maximum rating	Comment
31	Digital Input 4	Digital	From digital switch input 4. In a basic configuration this is usually the seat switch.	Type A $V = V_b$ See Table 3	See note to Table 3
32	Digital Input 7	Digital	From digital switch input 7.	Type B $V = V_b$ See Table 3	See note to Table 3
33	Motor thermistor in	Analogu e	From a thermistor device mounted inside the motor	$V = 5\text{ V}$ (via $2.2\text{ k}\Omega$ internal pull-up resistor)	A NTC thermistor having a resistance of approximately $2.2\text{ k}\Omega$ at $100^\circ\text{C}$ will give best sensitivity. Connect the other lead of the thermistor to the B-terminal of the Gen4 controller. Can also be used as an additional analogue input
34	Pot. 1 power supply +	Power	Supply feed to potentiometer 1. In a basic configuration this is the throttle.	$V = 10\text{ V}$ $I = 15\text{ mA}$	Suitable for potentiometers in the range $500\ \Omega$ to $10\text{ k}\Omega$
35	Pot. 2 power supply +	Power	Supply feed to potentiometer 2.	$V = 10\text{ V}$ $I = 15\text{ mA}$	Suitable for potentiometers in the range $500\ \Omega$ to $10\text{ k}\Omega$ . Alternative: Cos input from Sin-Cos analogue encoder, only if specified in h/w build

Table 2 Connector A pin out and wiring information

Controller voltage	Digital Input Type	Impedance to B+	Impedance to B-
24V/36V	A	9k	9k
	B	13k	9k
36V/48V	A	16k	16k
	B	24k	16k
72V/80V	A	44k	44k
	B	66k	44k
96V/110V	A	66k	66k
	B	100k	66k

Table 3: Impedance at Digital Input Pins

Note to Table 3:

Configure the digital input switches as active-high (switched to  $V_b$ ) or active-low (switched to battery negative). Configuration applies to all digital input switches (1 to 8) i.e. they are all active-high or all active-low. See section Digital inputs (page 6-14) for more details.

When a switch is open the digital input pin sits at approximately  $0.5 \times V_b$  (type 'A') or  $0.4 \times V_b$  (type 'B'). The input sinks current in active-high configurations and sources current in active-low configurations.



## Chapter 4: Specification

# Electrical

## Input voltage

	<b>24V only (Size 2 24V)</b>	<b>24/36V controllers</b>	<b>36/48V controllers</b>	<b>72/80V controllers</b>	<b>96/110V controller</b>
Conventional working voltage range (Note 1)	16.8V to 28.8V	16.8V to 43.2V	25.2V to 57.6V	50.4V to 96V	67V to 132V
Working voltage limits (Note 2)	12.7V to 34.8V	12.7V to 52.2V	19.3 V to 69.6 V	39.1 V to 116 V	48V to 150V
Non-operational overvoltage limits:	39.6V	59.4V	79.2 V	132 V	150V
Battery voltage droop:	Vnom to 0.5 x Vnom for 100 ms				
Input protection:	Input protected against reverse connection of battery				

Note 1: Conventionally the controller may be set to operate without cutback in the range 70% to 120% of the nominal battery voltage, although cutback parameters may be used to set cutbacks higher or lower than this range. Cutbacks are set by the user for various reasons, including:

- Battery protection against high current in deep discharge condition
- Providing smoothly reducing performance at extremes of working voltage range, rather than a sudden loss of function

Note 2: Working voltage range outside which the controller will be non-operational.

- Upper working voltage limits for 72V/80V Gen4 is being increased to 120V and will be rolled out when possible in future Gen4 variants for both PMAC and Induction motor firmware.

## Output protection

Output current:	Reduced automatically from peak to continuous rating depending on the time a peak load is applied to the controller (see Figure 10 on page4-4). Reduced automatically if operated outside normal temperature range.
Short-circuit:	Protected against any motor phase to B- or B+ at power-up. Protected against any motor phase to another motor phase at any time during operation. At switch-on Gen4 detects valid output loads are present before applying drive current.



---

CAUTION: Repetitive short circuits may damage the controller.

---

## Output ratings

Input (Vdc)	Function	Short term rating* (A rms)	Continuous rating** (A rms)
24	Single traction size 2	300	120
24/36	Single traction size 4	450	180
	Single traction size 6	650	260
36/48	Single traction size 2	275	110
	Single traction size 4	450	180
	Single traction size 6	650	260
72/80	Single traction size 2	180	75
	Single traction size 4	350	140
	Single traction size 6	550	210
96/110	Single traction size 4	300	120

\*2 minute rating (lower ratings are possible for longer periods; see example in Figure 10)

\*\* 1 hour minimum without forced-air cooling

Size 2 long-term rating achievable with finned heatsink approx 250mm x 180mm, 0.5°C/W

Size 4 long-term rating achievable with finned heatsink approx 330mm x 200mm, 0.3°C/W

Size 6 long-term rating achievable with finned heatsink approx 330mm x 280mm, 0.2°C/W

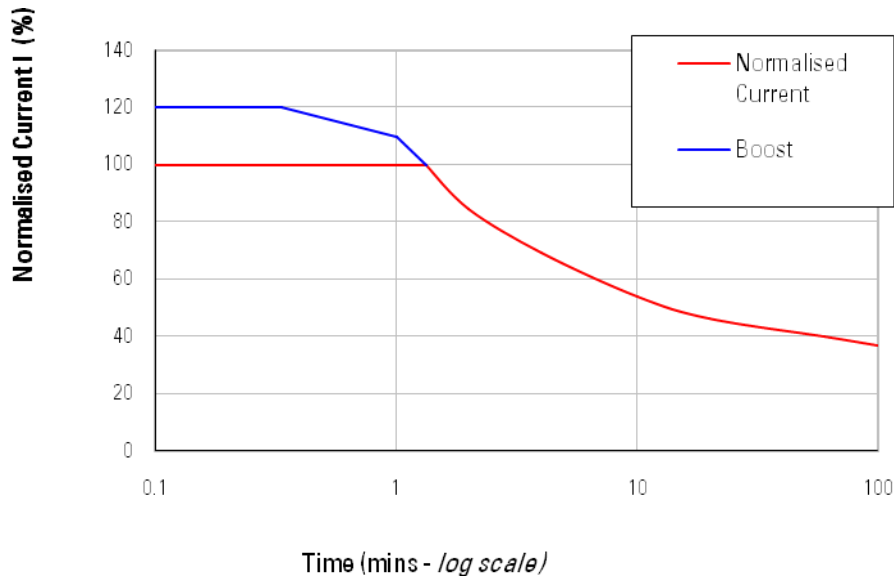

Figure 10 Output current available for various durations of sustained current demand



## CAN interface

CAN protocol:	CANopen profiles DS301, DS401 and DSP402 are supported. Physical layer uses ISO11898-2.
Baud rates supported:	1 Mbits/s (default), 500 kbits/s, 250 kbits/s, 125 kbits/s, 100 kbits/s, 50 kbits/s and 20 kbits/s.

## Control inputs and outputs

Digital inputs:	8 digital switch inputs (software configurable polarity). 24/36V controllers: Active low inputs < 2.6V, active high inputs > $V_b - 2.6 V$ 36/48V controllers: Active low inputs < 2.9V, active high inputs > $V_b - 2.9 V$ 72/80V controllers: Active low inputs < 4.4V, active high inputs > $V_b - 4.4 V$ 96/110V controllers: Active low inputs < 5.5V, active high inputs > $V_b - 5.5 V$
Analogue inputs:	2 general purpose inputs which can be used for 2-wire potentiometers, or as supplies for the 3-wire potentiometer wiper inputs. Motor thermistor input All analogue inputs can also be used as digital inputs.
Potentiometer wiper inputs:	Two 3-wire protected inputs.
Inductive drive outputs: (DO NOT USE WITH CAPACITIVE LOADS).	3 configurable PWM outputs. Use in voltage or current control mode. Voltage-controlled: Continuous sink current = 2A Peak current limited to < 2.5A Open-circuit detection ( $I_{out} < 0.1 A$ ) is a configurable option Short-circuit detection ( $I_{out} > 0.2 A$ ) when drive is in "off" state Voltage-controlled (PWM) mode allows contactors with a rating less than $V_{nom}$ to be used (range 24 V to $V_{nom}$ ). Current-controlled: Current output configurable between 0 and 2A
Motor speed sensor inputs:	Quadrature AB encoder signal inputs provided for control of induction motors UWV digital position sensor or sin-cos analogue position sensor inputs provided for control of permanent magnet motors

## Isolation

Any terminal to the case:	Meets EN1175-1:1998 and ISO3691 Complies with IEC-60664
---------------------------	------------------------------------------------------------

## EMC

Radiated emissions:	EN12895 (Industrial Trucks – Electromagnetic Compatibility) EN 55022:1998, 6, class B EN 12895:2000, 4.1 Emissions. When part of a system with a motor operating, FCC Part 15, Radiated Emissions. Meets the standards given in FCC Part 15, Section 15.109:
Conducted emissions:	No mains port, therefore not required
Susceptibility:	Performance level A (no degradation of performance) or level B (degradation of performance which is self-recoverable) subject to the additional requirement that the disturbances produced do not: <ul style="list-style-type: none"> <li>• affect the driver's direct control of the truck</li> <li>• affect the performance of safety related parts of the truck or system</li> <li>• produce any incorrect signal that may cause the driver to perform hazardous operations</li> <li>• cause speed changes outside limits specified in the standard</li> <li>• cause a change of operating state</li> <li>• cause a change of stored data</li> </ul>
Radiated RF field:	EN 61000-4-3, 5.1 Test Level: user-defined test level of 12 V/m EN 12895:2000, 4.2 Immunity EN 61000-4-6, Table 1 - Test Levels
Electrical fast transient:	EN 61000-4-4, Table 1 - Test Levels, Level 2
Electrostatic discharge:	EN 12895:2000, 4.2 Electrostatic Discharge 4 kV contact discharge 8 kV air discharge
Electrical surge:	EN 61000-4-5:1995, Table A.1 – Selection of Test Levels, Class 3

## Regulatory compliance

Designed to meet:	EN1175-1:1998 (which covers EN1726 for the controller) ISO 3691 UL583 ASME/ANSI B56.1:1993
-------------------	-----------------------------------------------------------------------------------------------------

# Mechanical

## Operating environment

Operating temperature:	-30°C to +25°C (no current or time derating) +25°C to +80°C (no current derating, but reduced time at rated operating point) +80°C to +90°C and -40°C to -30°C (with derating)
Non-operation temperature:	-40°C to +85°C (can be stored for up to 12 months in this ambient range)
Humidity:	95% at 40°C and 3% at 40°C
Ingress of dust and water:	Signal connector mated: IP66 rated (all sizes) Signal connector un-mated: IP66 rated (size 4 & 6 models) Signal connector un-mated: IP42 rated (size 2 models only)

## Shock and vibration

Thermal shock:	EN60068-2-14, Test Na
Repetitive shock:	50 g peak 3 orthogonal axes, 3+ and 3- in each axis, 11 ms pulse width
Drop test:	BS EN 60068-2-32:1993 Test Ed: Free fall, appendix B, Table 1
Bump:	40 g peak, 6 ms, 1000 bumps in each direction repetition rate 1 to 3 Hz.
Vibration:	3 g, 5 Hz to 500 Hz
Random vibration:	20 Hz to 500 Hz, acceleration spectral density 0.05 g <sup>2</sup> /Hz (equivalent to 4.9 g <sub>rms</sub> )

## Controller weight

Size 2:	1.3kg
Size 4:	2.7kg
Size 6:	4.6kg

Dimensions

Size 2 models

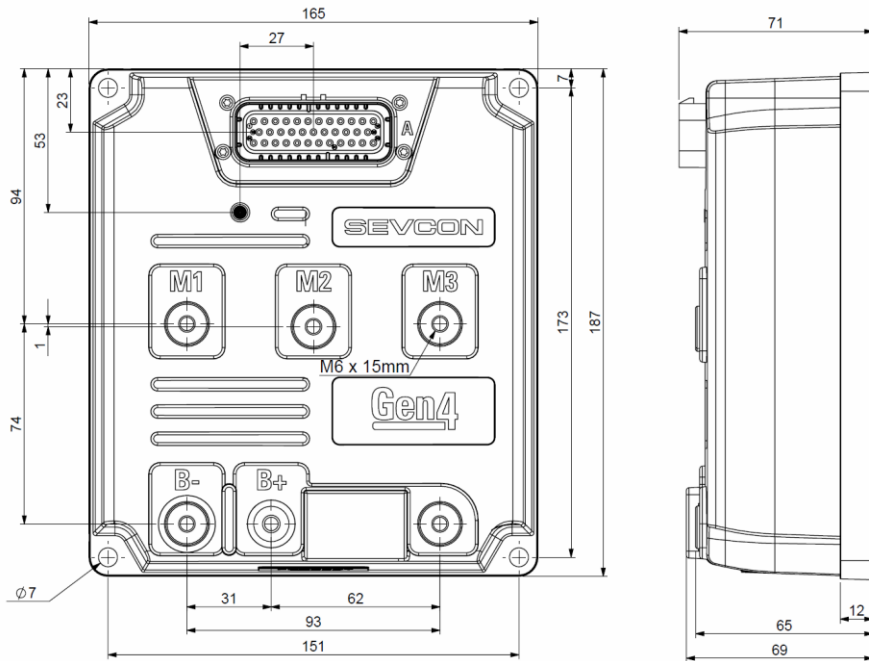
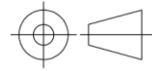

Size 4 models

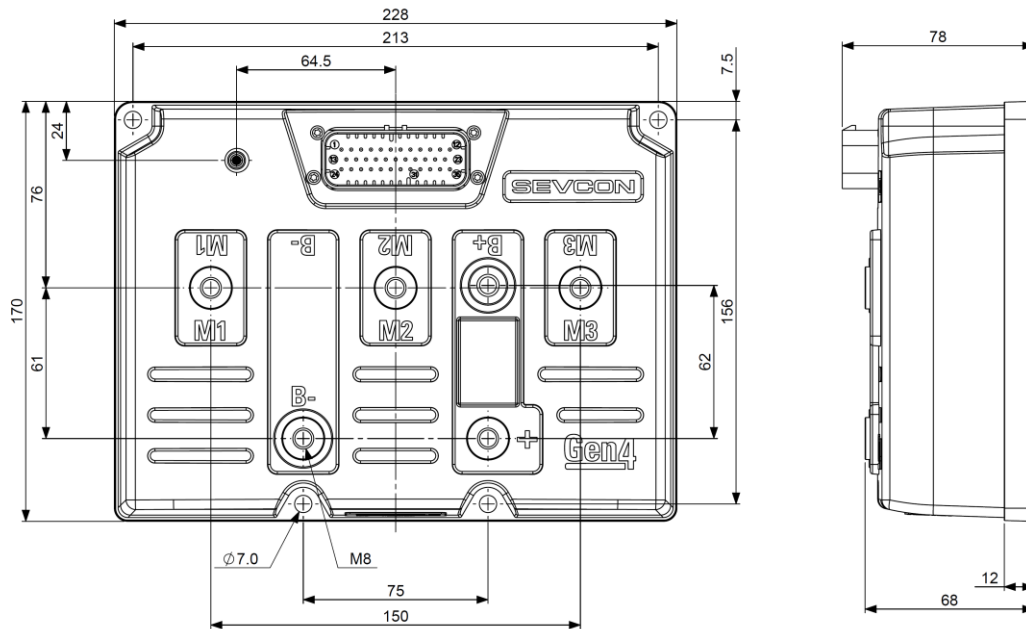

# Size 6 models

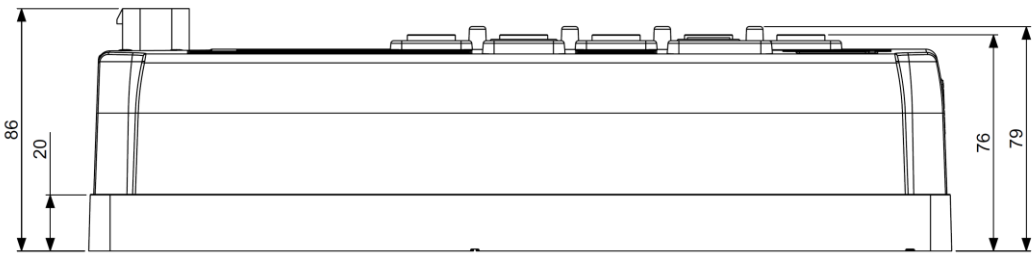
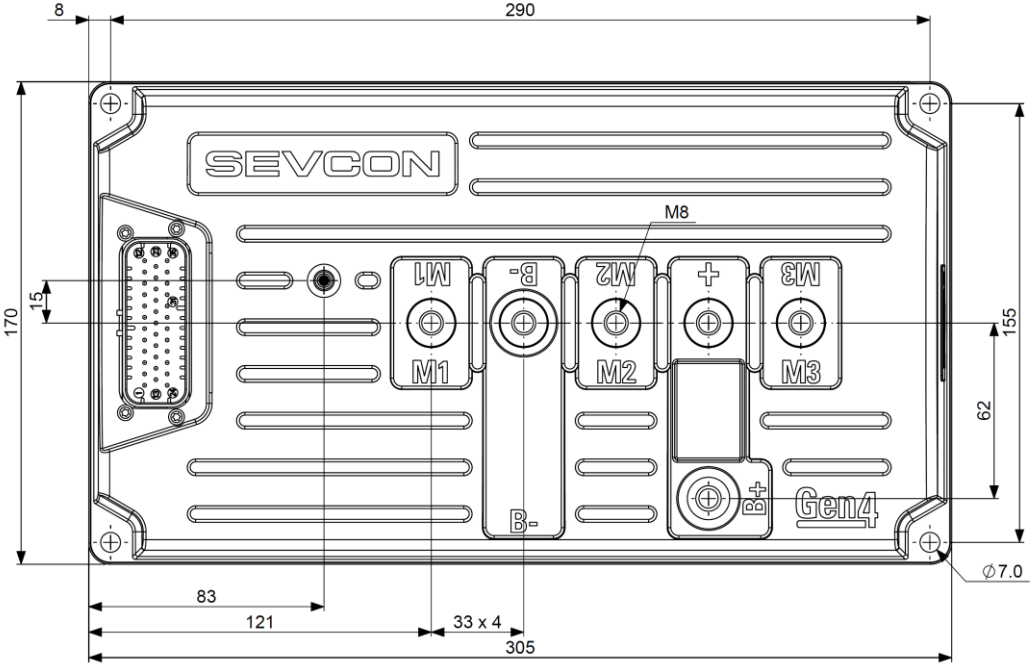
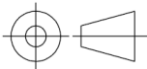



## Chapter 5: System design

# Sizing a motor

## Information required about the application

To select an appropriate induction motor for an application find or estimate the following information:

- Minimum battery voltage
- Maximum motor speed required
- Peak torque required at base speed
- Peak torque required at maximum motor speed
- Continuous (average) motor power output required to perform the work cycle
- Peak motor power output required and duration

Include inertia and friction contributed by the motor, as well as any gearing in the drive chain, when calculating torque and load requirements. If replacing a DC motor with an AC motor in an existing application, the DC motor torque vs. speed curve is a good starting point to determine the required ratings.

## Motor maximum speed

Determine the maximum motor speed using the required vehicle or pump maximum speeds and the ratio of any gear box or chain between the motor and the load. Most motor manufacturer rate induction motors at synchronous speed which is 1,500 and 1,800 rpm for a 4-pole motor when operated from 50 Hz and 60 Hz line frequencies respectively.

The maximum speed an induction motor can be used at is determined by the limit of the mechanical speed, typically 4,000 to 6,000 rpm, and the reduction in useful torque at higher speeds. Increasing losses in the iron of the motor at higher speeds may further limit the maximum speed. Always check the maximum speed with the motor manufacturer. Check also any limitations imposed by the maximum frequency of the encoder input signal (see 'Motor speed sensor (encoder)' on page 5-11).

## Torque required between zero and base speed

Calculate the torque required by the application. Use figures for the work that needs to be done against friction and gravity, plus those required to accelerate the load inertia and momentum. Up to rated speed the peak torque that can be supplied when using a correctly specified Gen4 is equal to the breakdown torque. Select a motor with a breakdown torque rating greater than the peak torque required.



## Torque required at maximum speed

Calculate the torque as above. As speed increases beyond base speed the maximum torque an induction motor can supply falls as defined by the following two equations:

In the constant power region;

$$T = \frac{T_{\max}}{\left(\frac{\omega}{\omega_{\text{rated}}}\right)}$$

In the high speed region;

$$T = \frac{T_{\max}}{\left(\frac{\omega}{\omega_{\text{rated}}}\right)^2}$$

This is shown in Figure 11. Select a motor with a torque rating greater than the peak torque required.

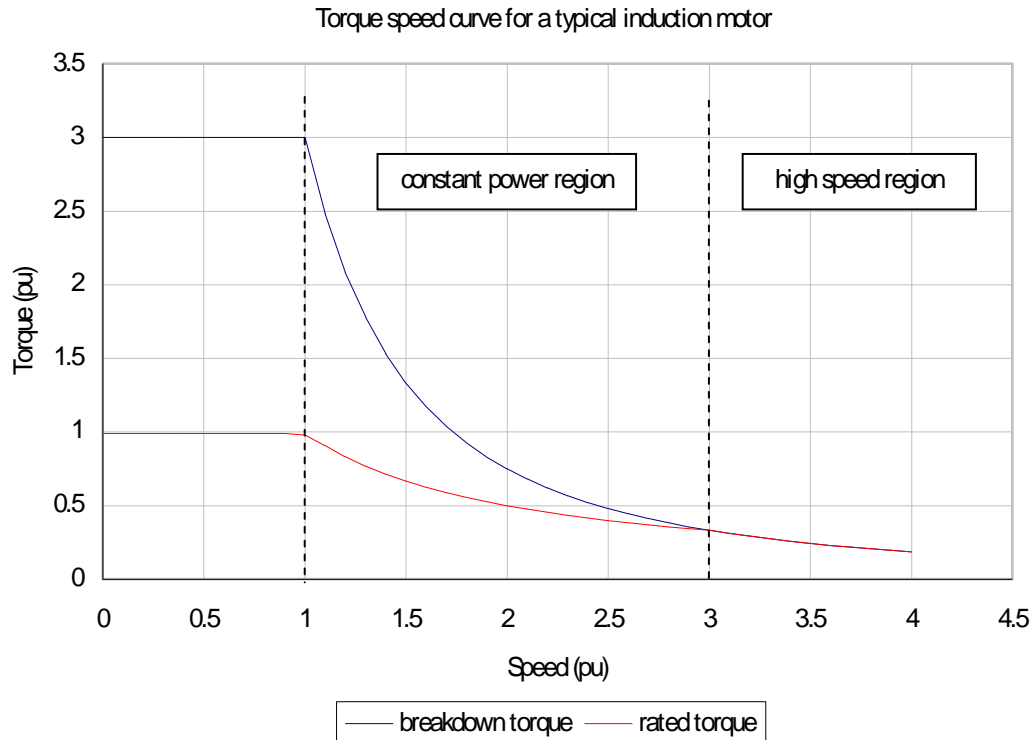

Figure 11 Torque speed curve

## Continuous power rating

The required continuous power rating of the motor is governed by the application load cycle over a shift. Use the maximum RMS current over a period of one hour to determine the motor rating required. The motor manufacturer will typically specify a 1 hour or continuous rating. Select a motor whose ratings are equal to or greater than your calculated load over 1 hour.

## Peak power rating

The peak power rating required for the application is actually determined by the peak torque required, as this determines the motor current required. Motor manufacturers will provide S1, S2 or S3 duty cycle ratings for the motors.

## Selecting the correct Gen4 model

Matching motor and controller ratings is not an exact exercise and therefore you may need to perform iterative calculations. The main considerations when choosing an appropriate Gen4 controller are described below.

### Current and power ratings considerations

Consider the following when choosing the appropriate Gen4 controller:

- Ensure the controller chosen matches or exceeds the peak current and average current requirements of the motor(s) in the application.
- Ensure the application can dissipate the waste heat generated by the controller. If the controller gets too hot it reduces its output, limiting vehicle performance.

### Power output restrictions at motor and drive operating temperature limits

A controller protects itself by reducing the current and hence torque available when its temperature limit is reached (Figure 12).

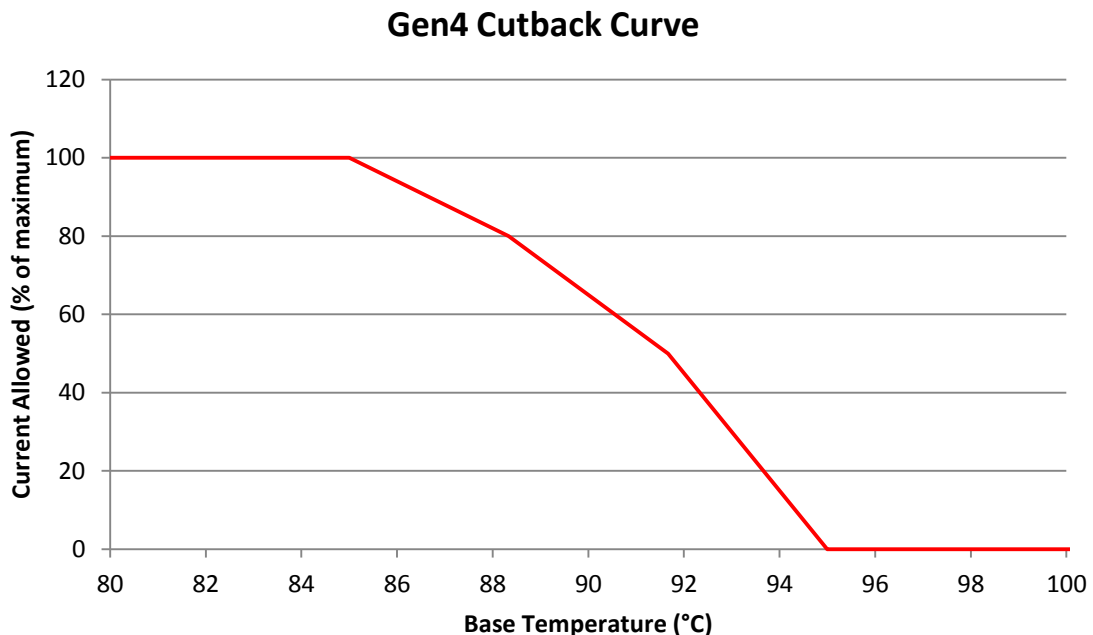

Figure 12 Current allowed vs. controller base temperature



---

*The Gen4 also looks at a number of internal temperature measurements and estimates. These can also influence the thermal cutback operation, depending on installation and operating duty cycle*

---

## Circuit configuration

Once motor size is determined the application circuit configuration can be defined. A basic single traction configuration (Figure 13) is provided as a starting point for new designs. Given the flexibility of the I/O it is possible to configure a wide range of systems. Refer to 'Signal connections' on page 3-14 to see what each I/O signal is capable of doing as you design your system. For pump applications a basic single pump system is shown in Figure 14.

# Single traction wiring diagram

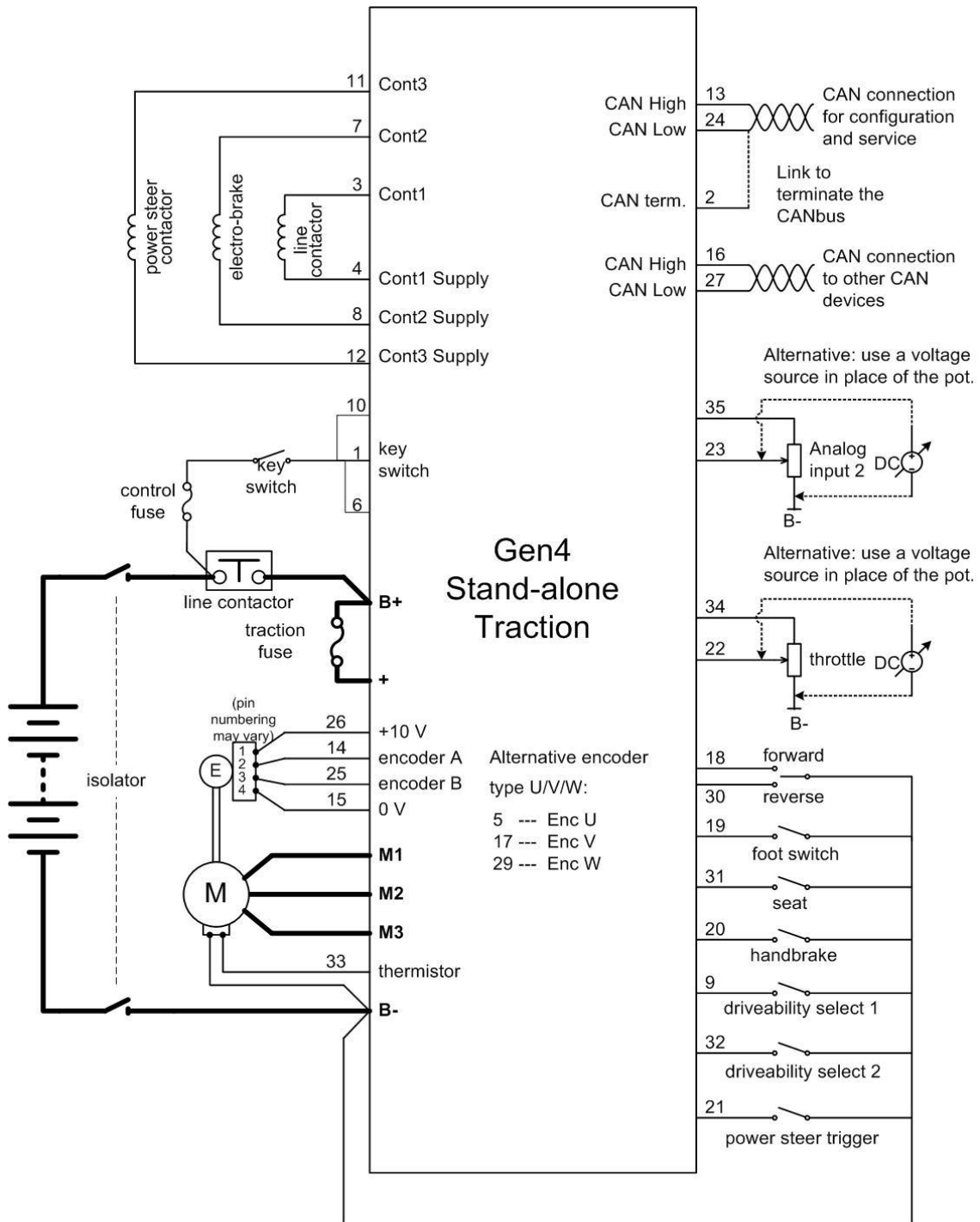

Figure 13 Single traction wiring diagram

Single pump wiring diagram

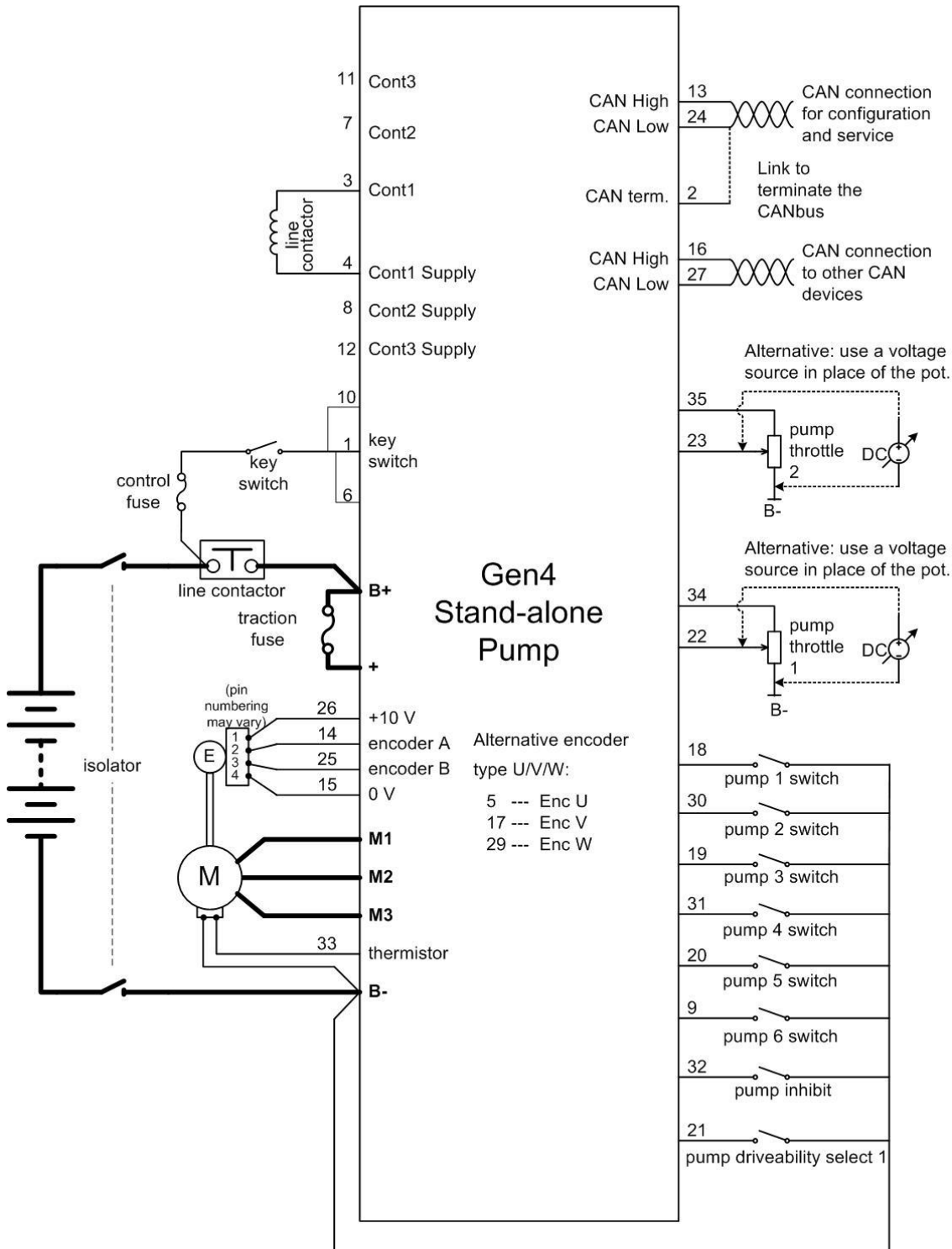

Figure 14 Stand-alone pump wiring diagram

# Twin motor systems

A twin motor system may be powered by two Gen4 controllers operating in master–slave configuration. In this case the necessary commands are transmitted by the master node to the slave node via the CANbus.

Motors may be operated independently in a combined traction-pump application or operated in tandem where each motor drives a separate wheel. In this latter case the controller (where there are two controllers, the controller configured as master):

- Assists in the steering of a vehicle by adjusting the torque of each motor dependent on the steering angle.
- Reverses the direction of the inner wheel in order to provide a smaller turning circle. The speed of the outer wheel is also limited during a turn.

An example of possible wiring for Gen4 traction controllers operating in master-slave configuration is shown in Figure 15.

## Auxiliary components

### Main contactor

Select the appropriate contactor line contactor from Table 4. A line contactor used at its rated coil voltage must be rated ‘continuous’. Contactor coil voltage chopping allows the use of coils rated ‘intermittent’, provided the manufacturer’s conditions are met.

<b>Gen4 peak output current</b>	<b>Coil</b>	<b>Sevcon P/N</b>	<b>Manufacturer</b>	<b>Notes</b>
Up to 450 A	24 V	828/37024	Albright SW200-29	See paragraph below
	48 V	828/57026	Albright SW200-20	
	80 V	828/67010	Albright SW200-460	
Up to 650 A	24 V	828/39001	Albright SW200	Chop at 17 V (intermittent coil)

Table 4 Main contactor rating

The controller can drive any contactor with coil voltages from 12 V to Vb. It is worth considering the use of 24 V contactors with the contactor drive output set to voltage-control mode. This allows you to use one type of contactor for any battery voltage (24 V to 80 V). Pull-in voltage, pull-in time and hold-in voltage values are all configurable.

Contactor coils must not be wired to the supply side of the key switch. Use the Output 1 Supply / Output 2 Supply / Output 3 Supply pins provided (see Table 2).

### 35 Way AMPSeal Connector Kit

Kit consists of Gen4 mating 35 way AMPSeal connector and pins, Sevcon p/n 661/27091

### Emergency stop switch

Refer to the appropriate truck standards.

## On-board fuse

See 'On-board fuse mounting' on page 3-11.

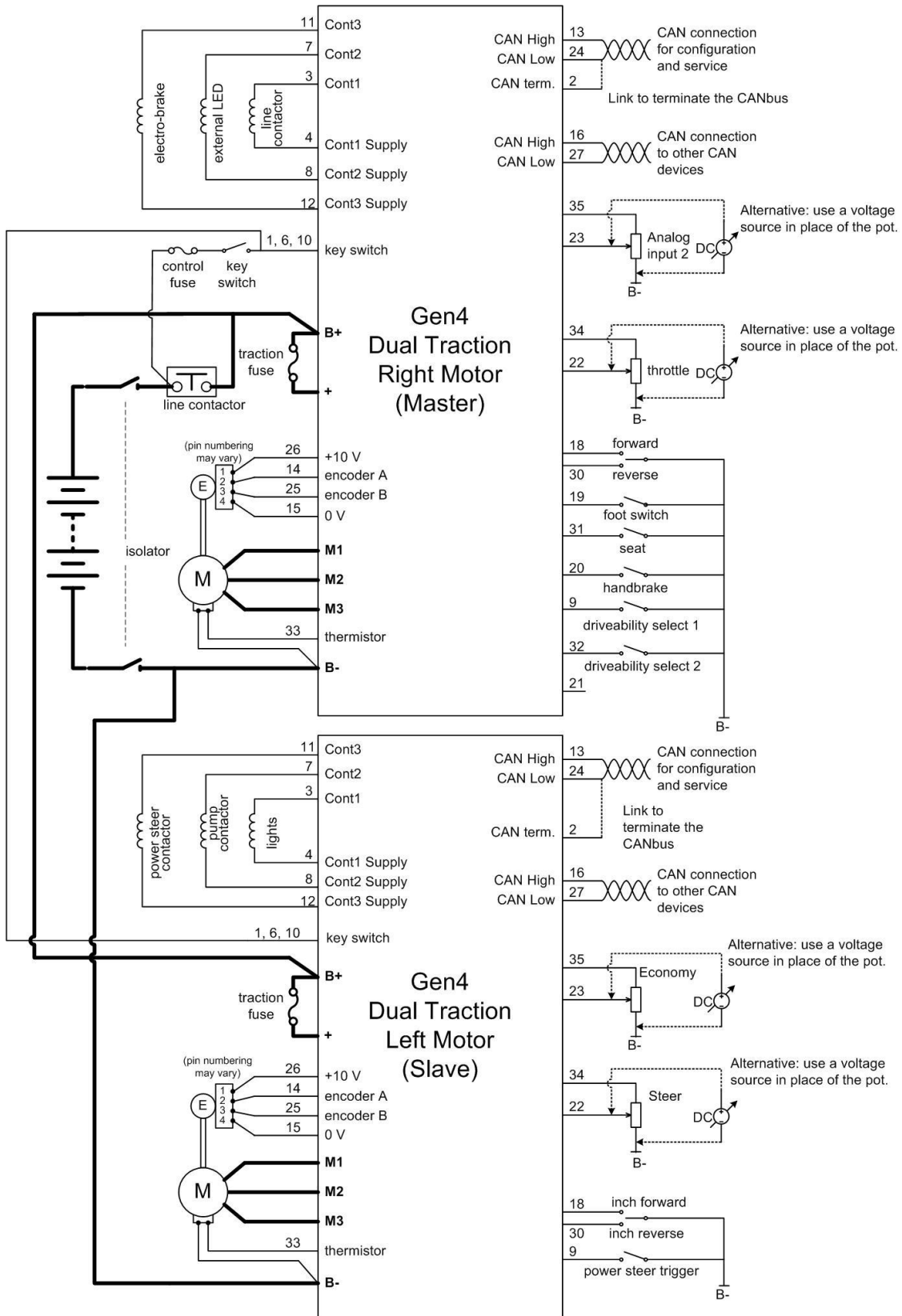

Figure 15 Dual traction wiring diagram



## Key switch fuse F2

Use a fuse rated for the larger of: A) the sum of the drive currents plus 1A for internal circuits, and B) the capacitor pre-charge circuit. In the following example there are two contactors each drawing 2 A:

	Device	Current
A	Line contactor	2 A
	Pump contactor	2 A
	Gen4 control circuits	1 A
B	Pre-charge circuit	7 A

Fuse choice: 7A.

## Motor speed sensor (encoder)

A 4-wire connection is provided for open-collector or current-source quadrature pulse encoder devices (software configurable). These types of encoder are optimized for accurate speed measurement, required for efficient control of induction motors.

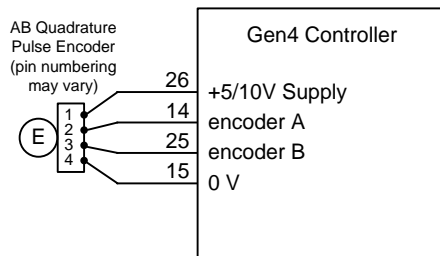

Figure 16 - Sample wiring for an AB quadrature speed encoder

You can use the following types of encoder, or equivalents:

Type	Output	Supply	Specification
Bearing Type (SKF and FAG)	Open collector	5 to 24 V DC	64 and 80 pulses per revolution Dual quadrature outputs Output low = 0 V (nominal)
HED Type (Thalheim)	Constant current	10 V nominal	80 pulses per revolution Dual quadrature outputs Output low = 7 mA Output high = 14 mA

Single channel encoders (without the encoder B connection) are also supported. However, when using this type of encoder, torque output is limited to the forward direction only. While these encoders can be used for belt drive or pump motors, the torque output limitation makes these unsuitable for traction applications.

The number of encoder pulses per revolutions (**n**) and the maximum motor speed (**N**) are related to, and limited by, the maximum frequency of the encoder signal ( $f_{max}$ ). The following table shows the maximum motor speed for a given encoder on a 4-pole motor.

Encoder ppr	Maximum motor speed (rpm)
128	6000
80	10000
64	10000

For other types of encoder and motor use the formulae:

$$f_{\max} (\text{Hz}) = \frac{n(\text{per revolution}) \times N(\text{rpm})}{60}$$

with  $f_{\max}$  limited to 13.3 kHz.

and

$$N_{\max} (\text{rpm}) = \frac{20000(\text{rpm})}{(p/2)}$$

Encoder PPR is set at 6090<sub>h</sub>. Additional encoder configuration (pull-up, supply, etc) is set at 4630<sub>h</sub>.



**Encoder PPR (6090<sub>h</sub>) must be configured correctly to ensure reliable control of the motor. Failure to do so could cause the controller to output incorrect torque.**

## Motor commutation sensor

### UVW Commutation Sensors

Commutation sensors are designed to measure the position of the rotor shaft within the motor, rather than its rotational speed. Rotor position information is used for control of permanent magnet motors, as it allows the controller to energise the motor phases appropriately based on the measured position of the magnets on the rotor.

The Gen4 controller provides inputs for both digital U/V/W style position sensors and analogue sin-cos sensors. Either of these can be used for control of permanent magnet motors.

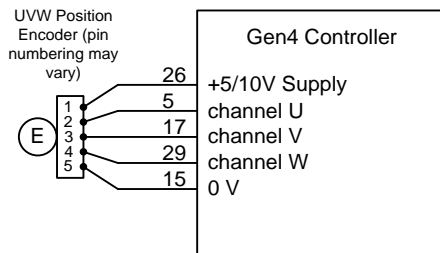

Figure 17 - Sample wiring for a UVW commutation sensor

3 digital inputs are provided for UVW encoders. The encoder should provide one pulse on each channel per electrical cycle of the motor, and each pulse should be 120° out of phase with the others and have a 50% duty cycle:

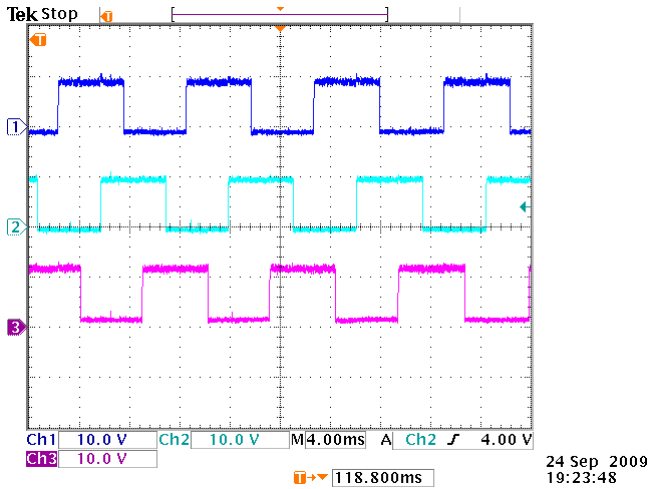

Figure 18 - Example pulse train from a UVW commutation sensor

UVW encoder power supply can be configured with 5V or 10V supply voltage. For 10V supply the low to high transition threshold is 5.3V and for 5V supply it is 2.7V

## Sin-Cos Commutation Sensor

Analogue sin-cos encoders should provide one sine wave and one cosine wave per mechanical rotation of the motor. Peak and trough signal voltages must have a minimum of 1V difference.

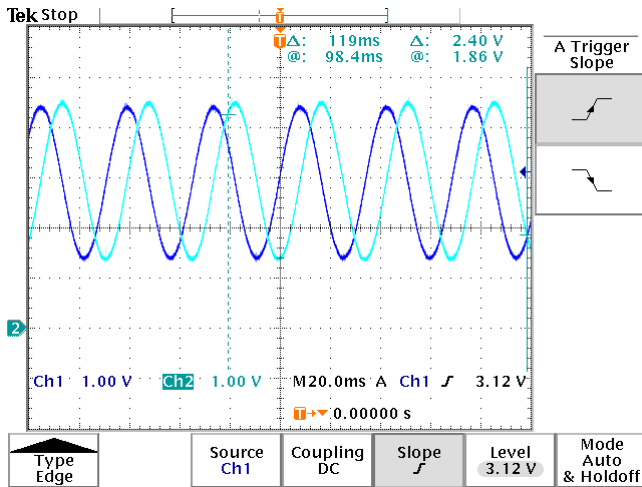

Figure 19 - Example of signals from a sin-cos position sensor

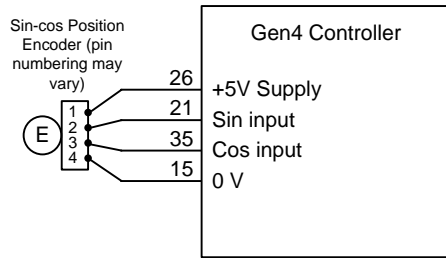

Figure 20 - Sample wiring for a sin-cos commutation sensor

Sin-cos encoders are typically powered by a 5V supply. Therefore it is important to ensure that the controller is configured to supply 5V on pin 26. This should be done by setting the encoder configuration object dictionary entry at  $4630_{h,n}$ .



---

*NOTE: The standard Gen4 build does not provide inputs for the sin and cos signals. Therefore, if operation with a sin-cos analogue encoder is required then this must be specified as a hardware build option. Controllers built for use with sin-cos encoders have the functions of pins 31 and 35 reassigned from digital and analogue inputs to sin and cos signal inputs respectively. Please contact your local dealer for more information on the sin-cos encoder build option.*

---





---

**Encoder offset ( $4630_{h,n,4+16}$ ), Sin/Cos Waves/Mechanical Revolution ( $4630_{h,n,14}$ ) and Sin/Cos Latency ( $4630_{h,n,15}$ ) must be configured correctly to ensure reliable control of the motor. Failure to do so could cause the controller to output incorrect torque.**

---

## Initial power up sequence

---

 **WARNING: Incorrectly wired or configured vehicles may behave in unexpected ways. Always confirm correct operation of the motor and encoder before lowering the drive wheels to the ground.**

---

### Checks prior to power up

Follow this checklist prior to applying power to your system:

- Jack up the vehicle so that the drive wheels are clear of the ground.
- Confirm all connections are tightened to specified level.
- Ensure all plugs are fully inserted.
- Confirm power wiring connections are made to the correct terminals (B+, B-, +, M1, M2 and M3).
- Ensure the controller is securely mounted (from a mechanical and thermal perspective).
- Ensure there is adequate and correctly ducted airflow for any fan cooling system.
- Check the routing of cables is safe with no risk of short circuit, overheating or cable insulation wear due to rubbing.

### Checks after power is applied

Apply power and do the following:

- Use Sevcon DVT (see page 6-2), the Sevcon Calibrator handset or any configuration tool to complete the configuration process which starts on page 6-7.
- Using the drive controls ensure the wheels rotate in the expected direction. If they do not, check the motor wiring, encoder wiring and encoder configuration (page 6-14).

It should now be safe to lower the vehicle to the ground and test drive. Proceed with caution.





## Chapter 6: Configuration

# Introduction

This section covers what you need to do to configure Gen4's software once you have designed and installed your hardware. All of Gen4's parameters have a default value and the amount of configuration needed is dependent on your particular system.

The main topics are:

- DVT configuration tool: installation and use
- CANopen: an introduction to the protocol and its use in Sevcon products
- An overview of the configuration process outlining what needs to be done and the order in which it must be done
- The configuration steps

## DVT configuration tool

DVT is Sevcon's proprietary configuration tool. It allows the user to monitor, configure and duplicate the parameters of any Sevcon CANopen node such as the Gen4 controller. The information presented here is an overview only. Contact Sevcon for more information about DVT and the functions it provides

## DVT functionality

DVT provides the following facilities:

- Configuration of controller IO, CANBus, motor parameters & vehicle drive performance parameters
- Loading DCF configuration file into the Sevcon controller
- Saving of DCF configuration file from controller to file on computer
- Controller status and fault diagnosis
- Data logging of controller/motor performance on test bench or vehicle
- Update controller firmware

## Saving, duplicating and restoring a node's configuration

You can use DVT to:

- Save a node's configuration. This can be used at some later date to clone the node's configuration.
- Duplicate a node's configuration, in real time, to another node on the CANbus.
- Restore a configuration to a node.

For example, if you want to save the Gen4 controller configuration, you will need to create a

DCF file. To do this, open the helper by clicking the  icon at the top of the DVT main window.



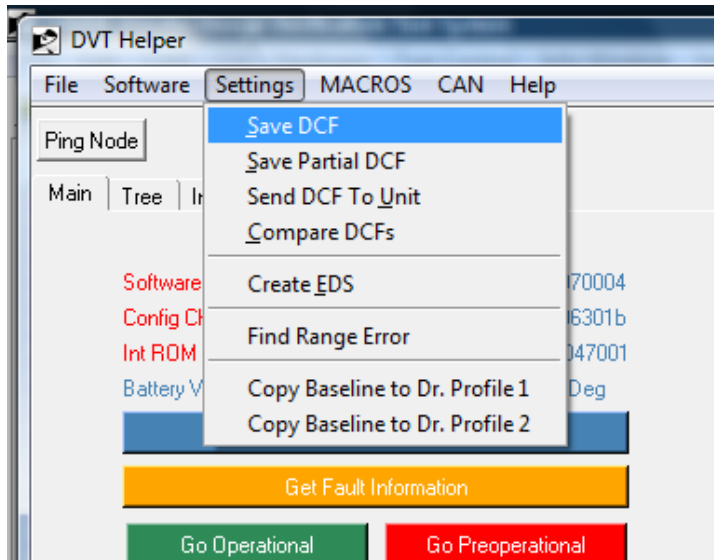

## Data Logging.

You can use DVT to monitor data or parameters of a Sevcon node in real time and graph the data.

## CANopen

This section assumes you have an understanding of CAN and are familiar with its use. If you are new to CAN or CANopen please refer to the CiA (CAN in Automation) website, [www.can-cia.org](http://www.can-cia.org) for further information.

The following information provides an introduction to the important CANopen terminology used in this manual and how it relates to the configuration of your Gen4 controller.

## CANopen protocol

CANopen is a CAN higher layer protocol and is defined in the DS301 'Application Layer and Communication Profile' specification. All CANopen devices must adhere to this standard. To provide greater standardization and interoperability with 3<sup>rd</sup> party devices, Gen4 is designed to use the CANopen protocol for communication on its CANbus and meets V4.02 of DS301.

CANopen also supports standardized profiles, which extend the functionality of a device. The controller supports the following CANopen standardized profiles:

- DS401 (V2.1) – Device Profile for Generic I/O Modules
- DSP402 (V2.X) – Device Profile for Drives and Motion Control

## Object Dictionary

Any device connected to the CANopen network is entirely described by its Object Dictionary. The Object Dictionary defines the interface to a device. You setup, configure and monitor your Gen4 controller by reading and writing values in its Object Dictionary, using a configuration tool such as Sevcon's DVT (see page 6-2).

There are two important text files associated with the Object Dictionary. These are:

### EDS (electronic data sheet)

An EDS is a text file representation of the Object Dictionary structure only. It contains no data values. The EDS is used by configuration software such as Sevcon's DVT to describe the structure of a node's Object Dictionary. An EDS for each Gen4 model and software version, is available from Sevcon. The EDS file format is described in the DSP306 – Electronic Data Sheet Specification.



---

*NOTE: Each Object Dictionary matches a particular Gen4 software revision, and its structure is hard coded into the controller software.*

---

### DCF (Device Configuration File)

This is a text file similar to an EDS except that it contains data values as well as the Object Dictionary structure.

DCFs are used to:

- Download a complete pre-defined configuration to a node's Object Dictionary.
- Save the current configuration of a node's Object Dictionary for future use.

## Communication objects

These are SDO (service data object) and PDO (process data object) as described below. There is a third object, VPDO (virtual PDO), used by Gen4 which is not a CANopen object. It is described here because its function is important and similar to that of a PDO.

### SDO (Service Data Object)

SDOs allow access to a single entry in the Object Dictionary, specified by index and sub-index. They use the client-server communication model, where the client accesses the data and the server owns the target Object Dictionary.

SDOs are typically used for device configuration (e.g. via DVT) or for accessing data at a very low rate.

### PDO (Process Data Object)

PDOs are used by connected nodes (for example in a twin motor configuration) to exchange real time data during operation. PDOs allow up to 8 bytes of data to be transmitted in one CAN message.

They use the producer-consumer communication model, where one node (the producer) creates and transmits the PDO for any connected nodes (consumers) to receive. Transmitted PDOs are referred to as TPDOs and received PDOs as referred to as RPDOs.

## VPDO (Virtual Process Data Object)

VPDOs do a similar job as PDOs for data exchange, but internal to a single Sevcon node. They are unique to Sevcon and are not part of CANopen.

## Network Configuration

### General

If non-Sevcon nodes need to be added, use the following procedure to setup the network:

1. Set node ID and baudrate in 5900<sub>h</sub> to the required values. Node IDs must be unique, and the baudrate must be the same for each node.
2. Set SYNC COB-ID in 1005<sub>h</sub> to 0x40000080 for the master node, or to 0x00000080 for all slave nodes. Bit 30 is set to indicate to a node if it is the SYNC producer. Only one node in the network should be configured as the SYNC producer. This should normally be the master. On the SYNC producer, set the SYNC rate in 1006<sub>h</sub>.
3. Set the EMCY message COB-ID to 0x80 + node ID in 1014<sub>h</sub>.

---

**WARNING: EMCY COB-IDs must be configured correctly to ensure the master handles EMCYs from slaves correctly.**

---



4. Configure the heartbeat producer rate in 1017<sub>h</sub>. This is the rate at which this node will transmit heartbeat messages.
5. Configure the heartbeat consumer rate in 1016<sub>h</sub>. A consumer should be configured for each node to be monitored.

---

**WARNING: Heartbeats must be configured correctly for correct network error handling. The master node should monitor heartbeats from all slave nodes. Slave nodes should, at a minimum, monitor heartbeats from the master node.**

---



6. On standalone systems with non-CANopen nodes attached, hardware CANbus fault detection should be enabled at 5901<sub>h</sub>. CANbus fault detection is automatically enabled for multi-node CANopen systems.
7. Configure additional SDO servers. An SDO server allows another CANopen device to SDO read/write from a node's object dictionary. Each node has one default SDO server (1200<sub>h</sub>) which is reserved for communication with configuration tools like DVT or the calibrator. Another 3 SDO servers can be configured at 1201<sub>h</sub> to 1203<sub>h</sub>. These should be used as follows:
  - a. On slave nodes, configure a server to allow the master node to communicate.
  - b. If there is a display in the system, configure a server to allow the display access.
8. On the master node, configure SDO clients at 1280<sub>h</sub> to 1286<sub>h</sub>. There must be one client for each slave node. The SDO clients must be configured to match the corresponding SDO server on each slave.
9. On the master node, list all slave node IDs at 2810<sub>h</sub>.
10. Configure RPDOs (1400<sub>h</sub> to 17FF<sub>h</sub>) and TPDOs (1800<sub>h</sub> to 1BFF<sub>h</sub>) appropriately for the system. See section, Object mapping (page 6-11), for more information.

11. Configure the RPDO timeout function if required. See section PDO mapping (page 6-12) for more information.

### 3<sup>rd</sup> Party CANopen Devices

At power up, the Gen4 master will communicate with all slave nodes to identify which nodes are Sevcon devices and which are not using the vendor ID in 1018<sub>h</sub>. This instructs the Gen4 how to handle EMCY messages from each node.

Gen4 knows how to react to EMCYs (faults) from Sevcon slaves and can take appropriate action. Gen4 does not know how to react to EMCYs from 3<sup>rd</sup> party devices, so the required fault reaction to 3<sup>rd</sup> party device EMCYs must be set at 2830<sub>h</sub>.

## Configuration process overview



**WARNING:** Electric vehicles can be dangerous. All testing, fault-finding and adjustment should be done only by competent personnel. The drive wheels should always be off the floor and free to rotate during the following procedures.



**NOTE:** We recommend saving parameter values by creating a DCF, before making any alterations so you can refer to, or restore the default values if necessary. Do this using DVT.

This part of the manual assumes you have a vehicle designed and correctly wired up with a CANopen network setup. Before you can safely drive your vehicle it is necessary to go through the following process in the order presented:

Step	Stage	Page
1	Motor characterization	6-8
2	I/O configuration	6-11
3	Vehicle performance configuration	6-18
4	Vehicle features and functions	6-34

### Access authorization

To prevent unauthorized changes to the controller configuration there are 5 levels of accessibility: (1) User, (2) Service Engineer, (3) Dealer, (4) OEM Engineering and (5) Sevcon Engineering. The lowest level is (1), allowing read only access, and the highest level is (5) allowing authorization to change any parameter.

To login with DVT, select User ID and password when prompted.

To login with other configuration tools write your password and, optionally, a user ID to object 5000<sub>h</sub> sub-indices 2 and 3. The access level can be read back from sub-index 1. The password is verified by an encryption algorithm which is a function of the password, user ID and password key (5001<sub>h</sub>).

The password key allows passwords to be made unique for different customers. The user ID also allows passwords to be made unique for individuals.

### How NMT state affects access to parameters

Some important objects can only be written to when the controller is in the pre-operational state. DVT takes Gen4 in and out of this state as required.

If you are not using DVT you may need to request the CANopen network to enter pre-operational before all objects can be written to.

To enter pre-operational, write '1' to 2800<sub>h</sub> on the master node.

To restore the CANopen network to operational, write '0' to 2800<sub>h</sub>.

The controller may refuse to enter pre-operational if part of the system is active: for example, if the vehicle is being driven. The request is logged in the EEPROM however, so if power is recycled the system won't enter operational and remains in pre-operational after powering up.

The NMT state can be read at 5110<sub>h</sub> where 05 = operational and 7F = pre-operational.

## Motor characterization

Ensure you have completed the CANopen network setup process.

### Determining motor parameters

To provide optimum motor performance Gen4 needs the basic motor information normally found on the name plate as well as the following information:

- A value for each of the electrical parameters of the induction motor as shown in Figure 21.
- The magnetic saturation characteristics of the motor in the constant power and high speed regions.
- Current and speed control gains.

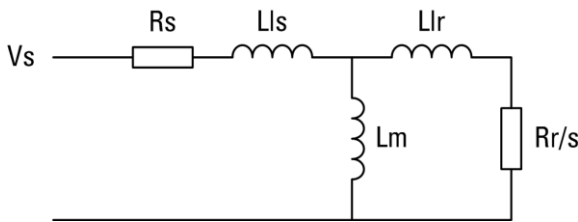

Figure 21 AC motor single-phase equivalent circuit

To determine these parameters use one of the following methods:

1. Ask the motor manufacturer to provide the data and enter it in the Object Dictionary at 4640<sub>h</sub> and 4641<sub>h</sub>. Also enter encoder data at 4630<sub>h</sub> and 6090<sub>h</sub> and motor maps at 4610<sub>h</sub> to 4615<sub>h</sub>. The motor maps are dependant on the motor type:

Motor Type	Map Object	Usage
PMAC	4610 <sub>h</sub>	Motor flux map showing torque versus magnetising current.
	4611 <sub>h</sub>	Motor power limit map showing maximum torque versus speed.
	4612 <sub>h</sub>	Voltage cutback map showing voltage versus torque reduction factor.
	4615 <sub>h</sub>	Second motor power limit map. Overrides map in 4611 <sub>h</sub> based on trigger defined in 4652 <sub>h</sub> .
Flux Vector	4610 <sub>h</sub>	Motor flux map showing torque versus magnetising current.
	4611 <sub>h</sub>	Motor power limit map showing maximum torque versus speed.
	4612 <sub>h</sub>	Voltage cutback map showing voltage versus torque reduction factor.

	4614 <sub>h</sub>	Saturation map showing magnetising current versus inductance.
	4615 <sub>h</sub>	Second motor power limit map. Overrides map in 4611 <sub>h</sub> based on trigger defined in 4652 <sub>h</sub> .
Open Loop Slip Control	4610 <sub>h</sub>	Motor flux factor map showing slip versus magnetising current factor. Used to give additional torque at low speed.
	4611 <sub>h</sub>	Motor power limit map showing maximum slip versus speed.
	4612 <sub>h</sub>	Voltage cutback map showing voltage versus torque reduction factor.

- Use the motor name plate data and the self characterization routine provided by Gen4 and DVT (described below).

The flux vector variant of software includes motor temperature compensation which can be used to adjust rotor resistance (4641<sub>h</sub>,8) with motor temperature. This is set at 4621<sub>h</sub>,4 to 7.

## Self characterization



**WARNING: The self characterization function will cause the motor to operate. Always ensure the vehicle is jacked up, with the driving wheels off the ground and free to turn before starting the test.**

The motor self-characterisation process allows a user to determine the electrical parameters required for efficient control of AC induction motors using a Gen4 controller connected to a PC or laptop running characterisation software. For further information, please contact your local Sevcon representative.

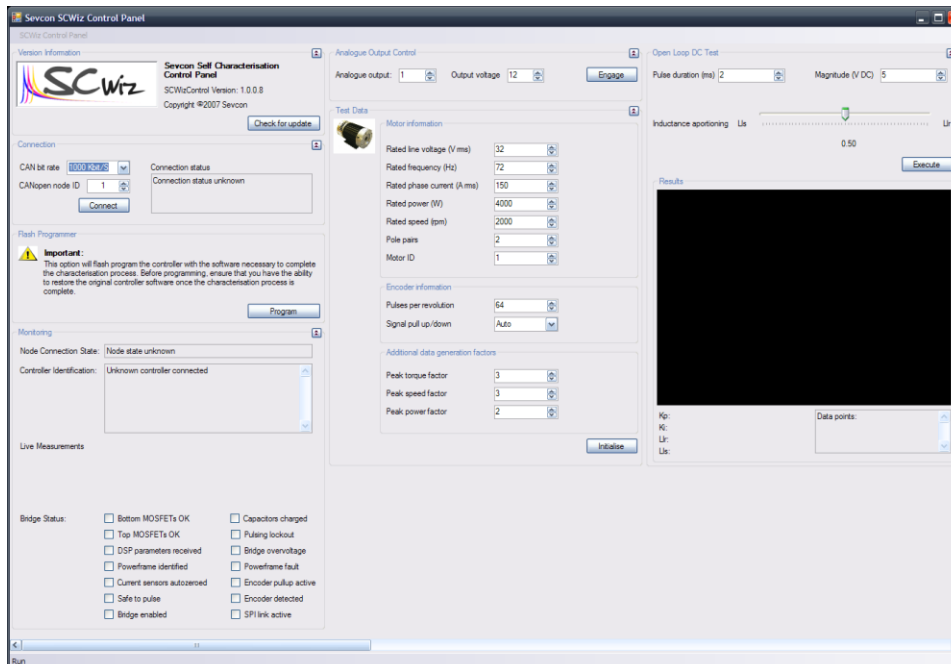



At time of writing, SCWiz is not yet compatible with 110V version of Gen4. Induction motor parameter characterisation therefore needs to be carried out using a lower voltage ( 48V or 80V) Gen4 controller.

## Additional Motor Configuration

The motor algorithms can be further configured using 4650<sub>h</sub>. Not all features are available for each motor type.

Feature	PMAC	FV	OLSC
Software over current disable. Set to disable software over current protection. Note that hardware over current protection is still active.	X	X	X
Low speed gain scheduling enable. If set, motor speed control algorithms interpolate gains from low speed to high speed gains from 25 RPM to 50 RPM, instead of the standard 50 RPM to 200 RPM.	X	X	
Current control gain scheduling enable. If enabled, current control proportional gains increase with frequency. Can reduce audible noise at low motor speeds.	X		
Drive/Braking torque inhibit to 0 RPM enable. If enabled, allows motor torque to be disabled to 0 RPM.	X	X	
Motor open circuit detection enable.		X	
Disable automatic discharge function for line contactor checks at power up	X		
Salient motor lookup table enable. If enabled, motor control uses lookup tables for salient motor control.	X		
Allow power frame to disable when motor is moving. If set, power frame can be disabled when no torque is demanded for 3s even if motor is rotating. <i>NOTE: PMAC software uses 5831<sub>h</sub> to configure bridge disable functionality.</i>		X	
Equal and opposite speed limits enabled. If set, speed limit (6080 <sub>h</sub> ) is applied in both directions.	X		
PI based Iq_max limit enable.	X		
Sin/cos min/max tracking algorithm disable.	X		



## I/O configuration

Ensure you have completed the CANopen network setup and Motor Characterization processes described above.

The individual characteristics and mapping of the I/O in your application need to be setup. This can be done manually, or one of a selection of predefined setups can be selected. Predefined setups exist for many of the common vehicle functions such as standalone traction, standalone pump and twin traction.

For configuration, it is necessary to use PDOs and VPDOs to map application objects on the master node (2000<sub>h</sub> to 24FF<sub>h</sub>) to the hardware I/O objects on all other nodes (6800<sub>h</sub> to 6FFF<sub>h</sub>). To configure I/O:

- **Either** configure PDOs and VPDOs to map application objects on the vehicle master node to hardware I/O objects on other nodes, **or** select a pre-defined configuration and use auto-configuration to set up PDOs and VPDOs
- Setup each hardware I/O object, including wire-off protection.

## Object mapping

To enable the controller to perform the functions required in your system it is necessary to map object to object (e.g. a measured input signal mapped to a steer operation).

This is achieved by setting up PDOs (node to node mapping) and VPDOs (internal mapping on each controller) as described below.

Apply mapping to Gen4 as follows:

- Standalone controllers: setup VPDOs only
- Networked controllers: setup VPDOs and PDOs



*NOTE: Before starting the mapping process it is a good idea to draw out a map of what you want to do. The amount of mapping required depends on the electrical wiring of your vehicle. Check to see if the default settings satisfy your needs before making changes.*

## VPDO mapping

VPDO mapping is defined by objects in the range 3000<sub>h</sub> to 3FFF<sub>h</sub> as shown in the table below. Use DVT, or any other configuration tool, to access these objects.

Feature	Object indices	Notes
Motor	3000h	Used to map the master to the type of local motor
Input mapping	3300h	Used to map digital input signals to application inputs
	3400h	Used to map analogue input signals to application inputs
Output mapping	3100h	Used to map application outputs to digital output signals
	3200h	Used to map application outputs to analogue output signals

To help understand how to map internal objects an example VPDO mapping is shown in Figure 22. A digital switch input is mapped to the seat switch function to control the traction application, i.e. with no seat switch input the vehicle is prevented from moving.

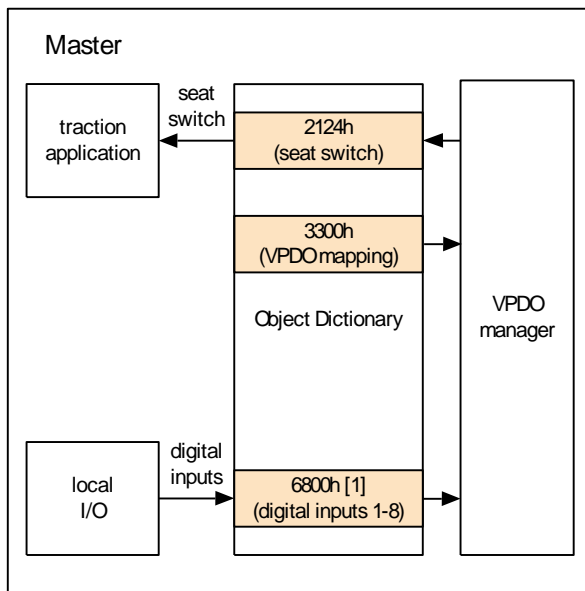

Figure 22 Example of a digital input mapped to the seat switch via VPDO

The number of sub-indices of each VPDO object depends on the amount of I/O on the device. For example, 3300<sub>h</sub> has 14 sub-indices on a device with 8 digital inputs and 5 analogue inputs. Sub-index 0 gives the number of I/O channels in use. In 3300<sub>h</sub> sub-indices 1 to 8 correspond to the digital inputs and sub-indices 9 to 14 correspond to the digital state of analogue inputs.

To map the local I/O to an application signal object, set the appropriate VPDO sub-index to the application signal object index. If the seat switch shown in the above diagram was connected to digital input 4 (bit 3 in 6800<sub>h</sub>,1), sub-index 4 of 3300<sub>h</sub> would be set to 2124<sub>h</sub>.

Some further examples are:

- Map FS1 to read the value of digital input 8 (connector A, pin 11): at 3300<sub>h</sub> sub-index 8 enter the value 2123<sub>h</sub>.
- Map the electromechanical brake signal to be applied to analogue output 2 (customer connector, pin 7): at 3200<sub>h</sub> sub-index 2 enter the value 2420<sub>h</sub>.

The data flow direction between the application signal objects and the local I/O objects depends on whether they are inputs or outputs. For inputs, the flow is from the local I/O to application objects, and vice versa for outputs.

Motor VPDOs are slightly different. There are six parameters for each motor, some of which flow from application to local I/O (controlword, target torque and target velocity) and some of which flow from local I/O to application (statusword, actual torque and actual velocity).

## PDO mapping

The controller supports 5 RPDOs (receive PDOs) and 5 TPDOs (transmit PDOs). Up to 8 Object Dictionary entries can be mapped to each PDO. Every PDO must have a unique identifier (COB-ID).

Setup RPDOs and TPDOs to transmit and receive events between nodes, and map I/O from one node to applications in another node.

The easiest way to do this is using DVT. If you are using a 3<sup>rd</sup> party configuration tool, the relevant Object Dictionary indices are listed in Table 5.

Feature	Object indices	Notes
Input mapping	1400h-15FFh	RPDO communication parameters
	1600h-17FFh	RPDO mapping
Output mapping	1800h-19FFh	TPDO communication parameters
	1A00h-1BFFh	TPDO mapping

Table 5 Objects associated with mapping

An example mapping (Figure 23) shows the movement of PDOs in a master-slave configuration in which a digital input to the slave has been mapped to the seat switch object in the master.

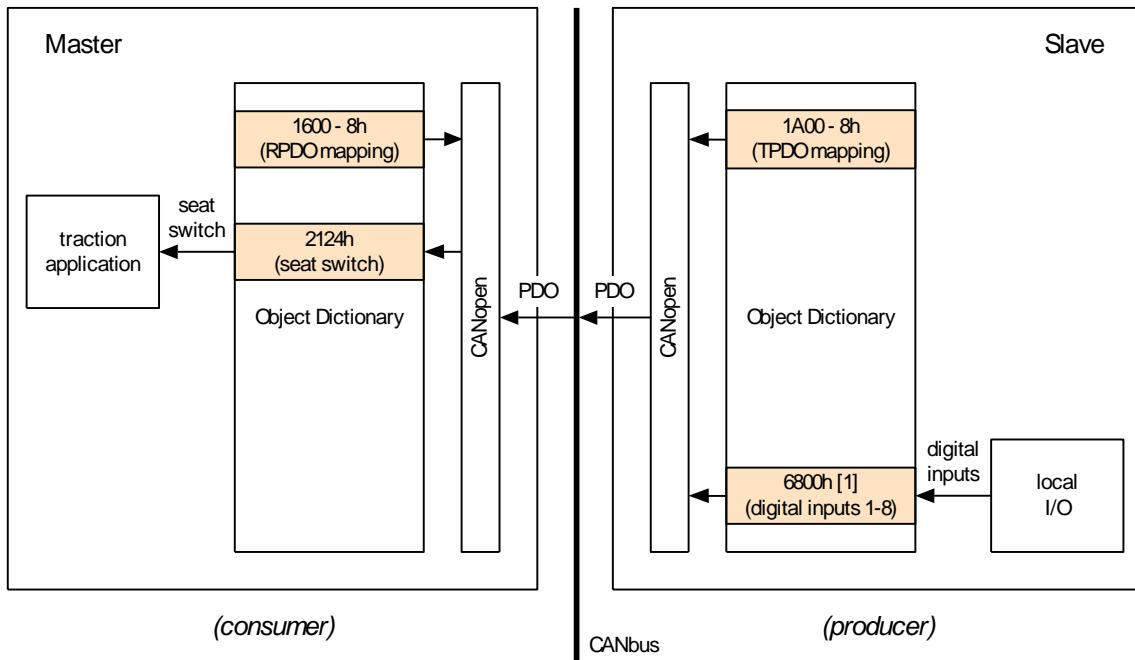

Figure 23 Example of a digital input mapped to the seat switch object via PDO and the CANbus

Gen4 supports RPDO timeout fault detection. This can set a warning, drive inhibit or severe fault depending on the configuration in 5902<sub>h</sub>.



**NOTE:** RPDO timeout can be used for non-CANopen systems which do not support heartbeating. By default, RPDO timeout is disabled, and normal CANopen heartbeating protocol (see section Network Configuration (page 6-5)) is assumed to be used.

## Encoder



**WARNING:** It is important that the number of encoder pulses per revolution is entered correctly. If this information is not correct, the controller may not be able to brake the motor effectively.

To configure the encoder:

1. Enter the resolution pulses/rev at 6090<sub>h</sub>.
2. Check whether the encoder requires controller pull ups enabled (e.g. open-collector type) and enable pull-ups if needed at 4630<sub>h</sub>. The default setting is no pull-ups, which is suitable for current source encoder types.
3. Select the required encoder supply voltage (10V or 5V) at 4630<sub>h</sub>.

To change the encoder polarity (if required) change the setting at 607E<sub>h</sub> (reverses the forward and reverse speed measurements).

Refer to the instructions in sections Motor speed sensor (encoder) (page 5-11) and Motor commutation sensor (page 5-12) for more information regarding encoder configuration.

Stall detection can be configured at 4626<sub>h</sub>. This can disable the torque in the event of a stalled motor or a failed incremental encoder.



*NOTE: Configurable internal pull-up is only available with inputs dedicated to AB encoder. UVW inputs always have internal pull-up present.*

## Digital inputs

The state of the digital inputs can be read at object 6800<sub>h</sub>.



*NOTE: Digital inputs are either all active low (switch return to battery negative) or all active high (switch return to battery positive). A mixture of active low and active high inputs is not possible. The default setting is active low.*

To configure digital inputs:

- Set active high/low logic at 4680<sub>h</sub>.
- Set wire off protection at 4681<sub>h</sub>. Any two digital inputs can be configured with wire-off protection. See Table 2 Connector A pin out and wiring information on page 3-19 (pins 14 and 15) for more details.
- Set digital input polarity at 6802<sub>h</sub>. This is used to configure normally closed/open switches.

## Analogue inputs

The analogue input voltages can be read at object 6C01<sub>h</sub>. Voltages are 16-bit integer values with a resolution of 1/256 V/bit.

Although each input is usually assigned a specific task by default, any of the inputs can accept a variable voltage or a potentiometer. Analogue inputs can also be used as additional digital inputs.

The following table summarises the analogue inputs and any special features:

Name	Object	Pin	Usage
Wiper Input 1	6c01 <sub>h</sub> ,1	22	Input from external voltage source or 3-wire pot wiper. Use pin 34 as supply for 3-wire pot.
Wiper Input 2	6c01 <sub>h</sub> ,2	23	Input from external voltage source or 3-wire pot wiper. Use pin 35 as supply for 3-wire pot.
Analogue Input 1 or Supply for Wiper Input 1	6c01 <sub>h</sub> ,3	34	Use for 2-wire pot input or as a supply for wiper input 1. Has internal pull-up.
Analogue Input 2 or Supply for Wiper Input 2	6c01 <sub>h</sub> ,4	35	Use for 2-wire pot input or as a supply for wiper input 2. Has internal pull-up.
Motor thermistor	6c01 <sub>h</sub> ,5	33	Use for motor thermistor input or 2-wire pot input. Has internal pull-up.

## Wire-off detection

Enable wire-off detection for analogue inputs at 46C0<sub>h</sub> to 46C4<sub>h</sub>. For each input specify the allowable range of input voltages. To disable, set the ranges to maximum.

## Motor thermistor input

You can connect a thermistor sensor to the Motor thermistor input or a switch to any digital input.

Type	Specification
PTC Silistor	Philips KTY84, KTY83 or equivalent
Switch	Connected to a general purpose digital input

To setup go to object 4620<sub>h</sub>:

- Configure as none, switch, PTC or CAN based thermistor
- For KTY84 thermistors, set the PTC type to KTY84.
- For KTY83 thermistors, set the PTC type to KTY83.
- For non-KTY84, KTY83 PTC thermistors, set the PTC type to User Defined and then set the expected voltages at 100°C (high temperature voltage) and 0°C (low temperature voltage). The Gen4 will linearly interpolate temperature with voltage.
- If you are using a switch select the digital input source
- For CAN based thermistors, the temperature can be loaded into object 4600<sub>h</sub> sub 16 using an RPDO.

Read the measured motor temperature (PTC) or switch operation at object 4600<sub>h</sub>.

## Analogue inputs configured as digital inputs

Each analogue input can also be used as a digital input.

To configure an analogue input as a digital input, set the high and low trigger voltages at object 4690<sub>h</sub>.

The digital input status object, 6800<sub>h</sub>, contains enough sub-indices for the digital and analogue inputs. Sub-index 1 is the states of the digital inputs, and sub-index 2 is the states of the analogue inputs converted to digital states.

## Analogue (contactor) outputs



**CAUTION:** Do not use contactors which have built in 'economiser' circuits, the internal circuits are not compatible with the controller and may cause malfunction or damage. The same power reduction can be achieved with a standard coil by using the configurable pull-in and hold voltage settings.

There are 3 analogue outputs which you may have mapped to one or more contactor functions such as: line contactor, pump, power steer, electro-brake, external LED, alarm buzzer and horn.

Configure each of the outputs used in your system:

- Choose voltage control or current control for each analogue output at 46A1<sub>h</sub>. (At the time of writing, current controlled devices can only be operated from Gen4 by mapping a signal input to the controller from an external 3<sup>rd</sup> party node).
- Set the frequency of each output to a fixed value of 16 kHz or any value between 40 Hz and 1 kHz at 46A2<sub>h</sub> and 46A3<sub>h</sub>. You can have only one low frequency setting per controller. Low frequencies are normally used with current-controlled outputs.
- Set the analogue output values at object 6C11<sub>h</sub>. The value is either a voltage or current depending on whether the output is voltage controlled or current controlled. Values are 16-bit integers with a resolution of 1/256 V/bit or A/bit.

## Error control



**WARNING:** It is important that analogue outputs on nodes other than the master must have appropriate error configuration to protect against CANbus faults. This section explains how to configure the outputs to go to a safe state in the event of a CANbus fault. It is the installers responsibility to define what a safe state is for each output.

In a CANopen network, the slave node on which the analogue (contactor) outputs reside can be different to the master node which calculates the output value. If the CANbus fails, the master node is no longer able to control the slave outputs. In this situation, the outputs may need to change to a safe value. This is achieved with error control.

To configure error control:

- Set each output at object 6C43<sub>h</sub> to use its last set value or the value at 6C44<sub>h</sub> if the CANbus fails.
- Set values if needed at 6C44<sub>h</sub> for each output. These values are 32-bit integers, but the bottom 16-bits are ignored. The top 16-bits give the error value in 1/256 V/bit (or A/bit for current controlled outputs).

Some examples of typical configurations may be:

- Electro-mechanical brake on slave node. If CANbus communication is lost, it may be desirable to apply the electro-mechanical brake on the slave device. In this case, enable error control in 6C43<sub>h</sub> and set the error value in 6C44<sub>h</sub> to 0.
- Power steer contactor on slave node. If CANbus communication is lost, it may be desirable to leave the power steer output in its previous state. In this case, disable error control in 6C43<sub>h</sub>.

- CANbus communication error lamp on slave node. If CANbus communication is lost, it may be desirable to activate an output on the slave device. In this case, enable error control in 6C43<sub>h</sub> and set the error value in 6C44<sub>h</sub> to an appropriate voltage for the lamp.



---

*NOTE: The above examples are for illustration purposes only. It is the responsibility of the installer to decide on the required state for each output in the event of a CANbus failure.*

---

# Vehicle performance configuration

Ensure you have completed the CANopen network setup, Motor Characterization and I/O Configuration processes described above.

## Safety Interlocks

### FS1

The FS1 switch is normally part of the throttle assembly. It closes when the throttle is pressed. The throttle voltage is ignored until FS1 is closed.

FS1 features are configured at 2914<sub>h</sub>:

- SRO (static return to off): inhibits drive if FS1 is closed for the SRO delay without any direction (forward or reverse) being selected.
- FS1 recycle: forces the operator to lift their foot off the throttle before allowing drive after a direction change.

### Deadman

The deadman switch operates similar to the FS1 switch, whereby, it inhibits drive until it is active. However, the deadman switch applies the electro-mechanical brake immediately on deactivation, whereas FS1 waits for the vehicle to stop before applying the brake.

### Seat

The seat switch indicates operator presence on the vehicle. Drive is not allowed if this switch is open. If the seat switch opens during drive for a period longer than the seat switch delay, a fault is set, disabling drive. To clear a seat fault, close the seat switch, open FS1 and deselect the forward/reverse switch.

Set the seat switch delay at object 2902<sub>h</sub>.

### Handbrake

If mapped to a digital input, the handbrake switch inhibits drive if the vehicle handbrake is applied. Controlled roll-off detection is still active when the handbrake is applied in case the brake fails.

### Sequence Fault Masking

If an application does not require it, sequence fault checking can be disabled on selected drive inputs. This is set at 2918<sub>h</sub>.

Similarly, drive inputs can be masked when clearing drive inhibit faults. This is set at 291A<sub>h</sub>.



**CAUTION:** These masks must only be applied if the application has other adequate means of protection. It is the responsibility of the installer to ensure this.

---



## Torque mode/speed mode

---



**WARNING: Speed mode (or speed control) is not recommended for on-highway vehicles as it can cause the traction motor/wheel to remain locked or brake severely if the wheel is momentarily locked due to loss of traction on a slippery surface and/or mechanical braking.**

---

The Gen4 controller provides both torque and speed control modes. Objects 2900<sub>h</sub> and 6060<sub>h</sub> are used to set which mode to use. The default setting is torque mode.

---



**WARNING: Always ensure 2900<sub>h</sub> on the master node and 6060<sub>h</sub> on all the traction nodes (master and slaves) match otherwise motor signals between the master and slaves may be misinterpreted.**

---

The speed control (speed mode) or speed limit (torque mode) is controlled using PI loops. These loops are configured at 4651<sub>h</sub>. The following parameters can be configured:

- Standard proportional and integral gains (4651<sub>h</sub>, 1+2). Used to configure the loops during normal operation.
- Low speed proportional and integral gains (4651<sub>h</sub>, 3+5). Used to configure the loops at low speeds (<50 RPM) and during hill hold. These are normally set lower than the standard gains to dampen oscillation as the vehicle comes to a stop.
- Roll back integral gain (4651<sub>h</sub>, 4). Used to boost the integral term to prevent vehicle roll-off down inclines, particularly when Hill Hold is enabled. Normally, this gain is higher than the standard integral gain.
- dw/dt gain (4651<sub>h</sub>, 6). For speed mode this is used to boost the torque output when a large increase in speed demand occurs. For torque mode this is used to apply compensatory torque to damped oscillations induced from the vehicle drive train.
- Integral initialization factor (4651<sub>h</sub>, 7). Used to initialize the integral term on entry to speed limit in torque mode. This factor is multiplied by the actual torque to set the integral term. Not used in speed mode.
- Speed filter pole (4651<sub>h</sub>, 8). Used to filter speed used by speed limit loop.
- Speed pre-limit threshold (4651<sub>h</sub>, 9). Speed limit algorithm will start cutting back torque when speed is within this threshold of the maximum.
- Opposing maximum speed limit ramp rate (4651<sub>h</sub>, 10). Rate at which opposing speed limit ramps back to 0 RPM.

These settings affect how driver demands are interpreted by the controller. In torque mode, the throttle push translates into a torque demand, which is applied to the traction motor. In speed mode, the throttle push translates to a speed demand. The controller then calculates the torque required to maintain this speed.

The difference between these control methods is most apparent when driving on an incline. In torque mode, when the vehicle is driven uphill, the vehicle speed will decrease due to the increased load. The operator must apply more throttle demand in order to maintain speed. In speed mode, the controller will apply additional torque in order to maintain the operator's speed demand, without the operator having to increase throttle demand.

# Throttle

## General

The controller can use 2 or 3 wire throttle inputs of the following types:

- Linear potentiometer in the range 470  $\Omega$  to 10 k $\Omega$
- Voltage source in the range 0V to 10V: compliant with the standard 0..5 V, 0..10 V or 3.5..0 V ranges

To setup throttle inputs see 'Analogue' on page 6-14. The throttle voltage (2220<sub>h</sub>) must be mapped to an analogue input.



**CAUTION:** Inputs with wire-off detection should be used for the throttle input to detect wiring faults. This is especially important if a wire-off sets maximum throttle. See section Analogue inputs (page 6-14) for more information. Configure throttle wire-off detection threshold at 2910<sub>h</sub>, 21.

Setup the characteristics of the throttle at 2910<sub>h</sub>, sub-indices 2 to 21.

- Define the throttle voltage input: this is the relationship between the throttle voltage and the throttle value. Separate relationships can be specified for forward and reverse. Each relationship has two points, a start and an end. The points are configured differently for standard and directional throttles as shown in Figure 24 and Figure 25 respectively.

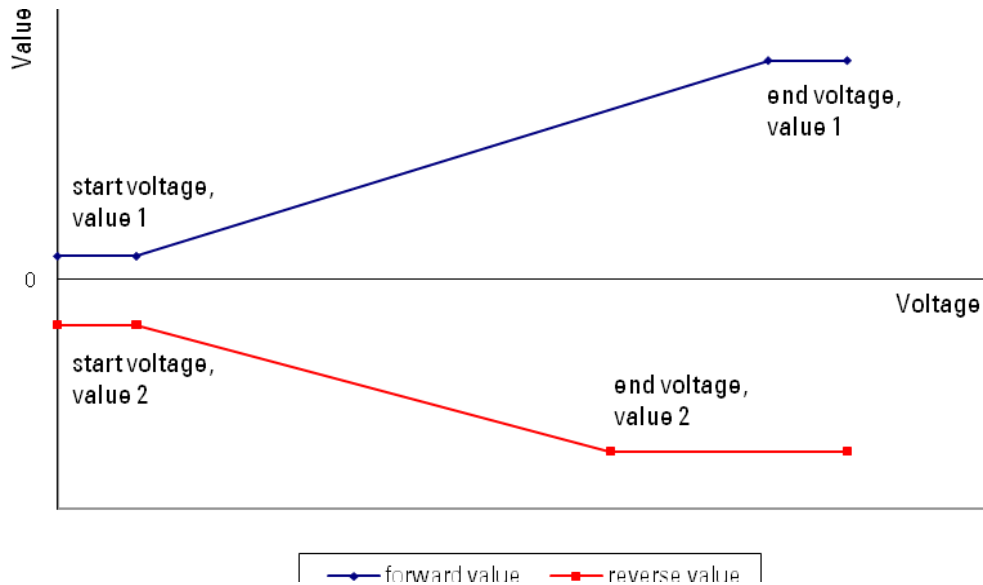

Figure 24 Standard throttle configuration



*Note:* If the reverse characteristic is the same as the forward characteristic, just set all the reverse throttle parameters to 0 in 2910<sub>h</sub>.

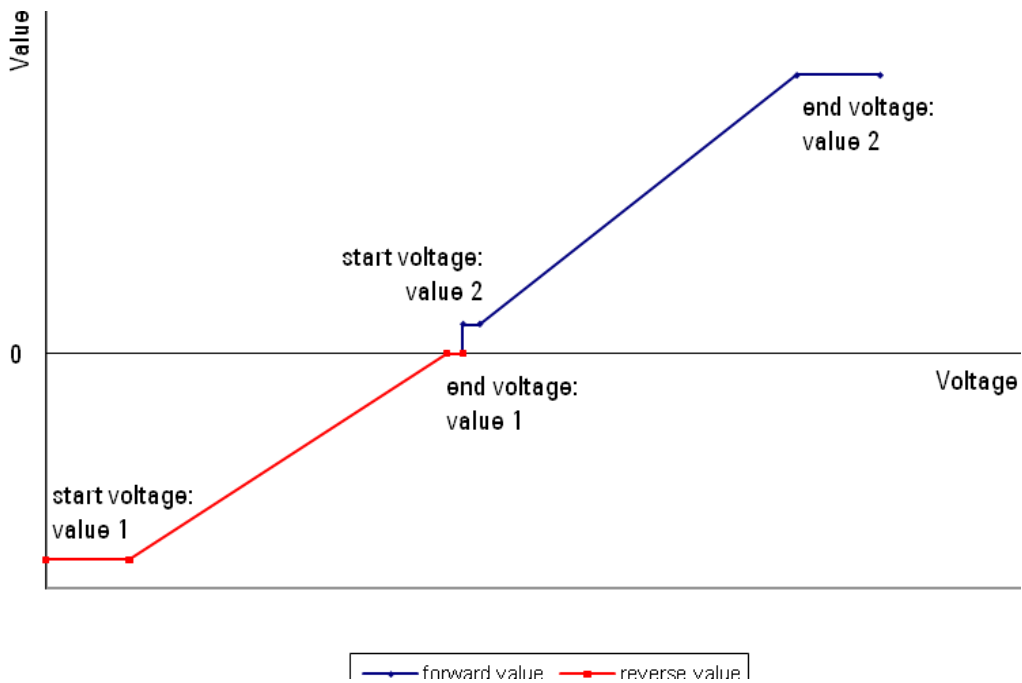

Figure 25 Directional throttle configuration

- Define the input characteristic: this is a profile to the throttle value and can be linear, curved, crawl or user-defined as shown in Figure 26. The curved and crawl characteristics give greater throttle control at low speeds.

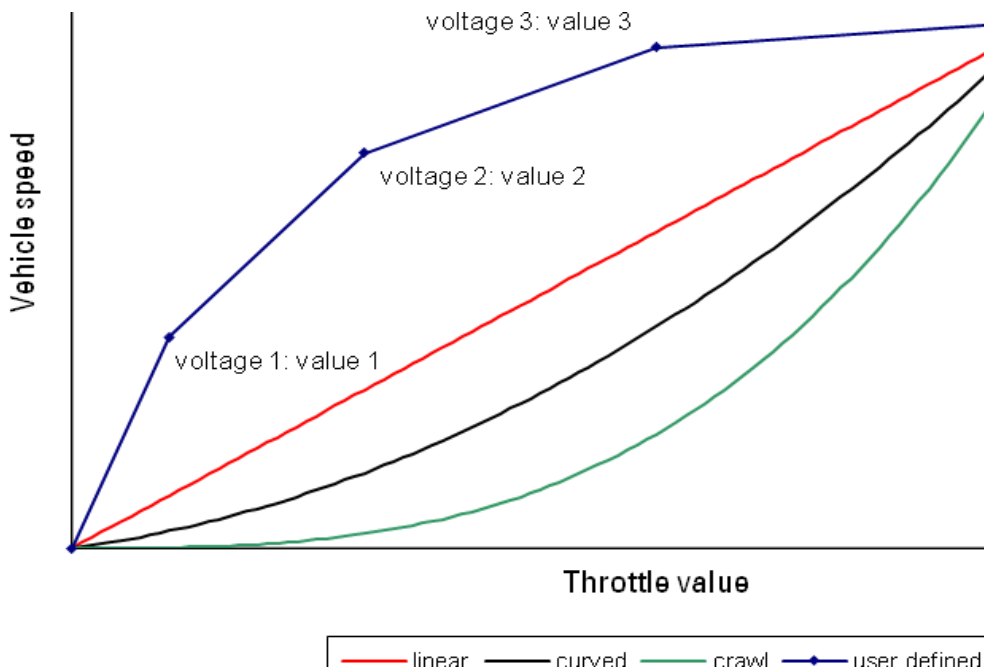

Figure 26 Input characteristics

The throttle value calculated from the voltage can be read at 2620<sub>h</sub>.

## Dual Throttle Inputs

Single and dual throttle inputs are supported.

Single throttle inputs are normally used with other interlock inputs (eg FS1, deadman, etc) and use a single input voltage to determine driver demand.

Dual throttle inputs use two separate input voltages, each of which is converted to a throttle value using 2910<sub>h</sub>, sub indices 3 to 6 (throttle input 1) and sub indices 7 to 10 (throttle input 2). If the throttle values differ by more than 5%, a throttle fault is set and the system will not drive.

To enable dual throttle functionality, map a second analogue input to 2224<sub>h</sub>. The throttle value for the second throttle input can be read at 2626<sub>h</sub>.

Dual throttle systems allow a virtual FS1 feature, which can be used instead of an actual FS1 switch. This feature can be enabled on dual throttle systems using 2910<sub>h</sub>, 1.



---

CAUTION: The voltage input characteristics of the two analogue throttle inputs must be different.

---

## Creep Torque

Set creep torque at 291f<sub>h</sub>. Creep torque allows a small amount of torque to be applied as soon as the throttle is closed. This can be used on some vehicles to overcome the friction required to achieve initial vehicle movement.

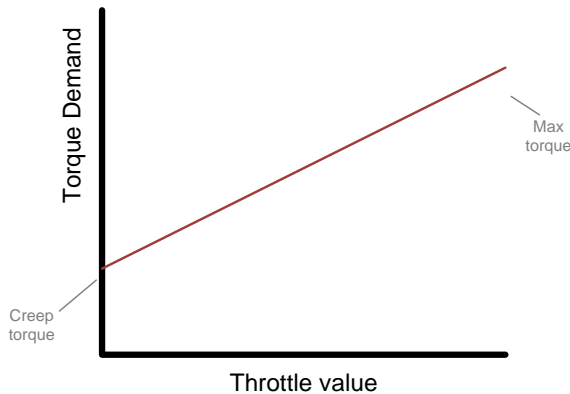

Figure 27 - Illustration showing behaviour of creep torque

Increasing the creep torque level can improve how the vehicle feels when drive is first selected and the vehicle starts to move. However, too much creep torque can make the vehicle uncontrollable at low speeds.



---

CAUTION: Creep torque will be applied as soon as drive is selected and the throttle is closed. Do not increase the creep torque value to a level that would cause unexpected high levels of torque output for comparatively low levels of throttle push. If in doubt, set the creep torque level to 0%.

---

## Driveability Features



---

CAUTION: These features are used to configure how the system uses throttle information and how it handles speed limits (in torque mode). The installer must ensure these features are configured appropriately.

---

Set the following driveability features at 2910<sub>n</sub>, 1:

- Enable/disable proportional braking. If enabled, the braking torque during direction braking is proportional to the throttle.
- Enable/disable directional throttle. If configured as a directional throttle, the throttle voltage indicates the direction as well as the speed demand. This removes the need for forward and reverse direction switches.
- Proportional speed limit enable/disable. If enabled, speed limit is proportional to the throttle, otherwise speed limit is fixed at the forward or reverse maximum speed. Only used in torque mode.



---

**WARNING: Proportional Speed Limit is not recommended for on-highway vehicles as it can cause the traction motor/wheel to remain locked or brake severely if the wheel is momentarily locked due to loss of traction on a slippery surface and/or mechanical braking.**

---

- Braking directional throttle enable/disable. If enabled, a directional throttle can be used to demand a drive or braking torque in conjunction with the direction switches. Only used in torque mode.
- Reverse speed limit encoding. Controls how reverse speed limits are handled in torque mode. Must always be enabled on Slip control systems, and must always be disabled on flux vector and PMAC systems.
- Handbrake fault. If enabled, a handbrake fault is set when a direction is selected whilst the handbrake input is active.
- Proportional speed limit during braking enable/disable. If enabled, speed limit is proportional to throttle only in drive states. Maximum speed limit is allowed in braking states. Only used in torque mode.
- Driveability Consolidation. Normally, driveability profiles are only used to reduce vehicle performance, however, if this is enabled, an active driveability profiles over-writes the baseline. This allows vehicle performance to increase when a profile is active. Note, that this feature is not available in all software builds.
- Allow step change in steering angle. If enabled, steering angle can change instantly with steering voltage. If disabled, steering angle is rate limited to 90°/s which prevents sudden steering angle changes in the event of a steering sensor wire-off.
- Virtual FS1 enable/disable. If enabled, this sets up a virtual FS1 feature on systems with dual throttle inputs configured.
- Positive (absolute) Steer Angle only enable/disable. If enabled steer angle is always positive in both directions. Used for single traction systems with steering cutback. Motor mapped must be left motor
- Separate Seat Regen Braking enable/disable. If enabled, separate regen setting is activated for regenerative braking with operator off the seat. Seat Regen settings are set at 2928<sub>n</sub>.
- Slave Left Motor Speed Inversion enable/disable. Inverts left motor slave actual speed when slave inversion switch activates.

An s-curve profile can be applied to the speed target (in speed mode) or maximum speed (in torque mode). This can be set at 290A<sub>n</sub>.

## Acceleration and braking

See 'Driveability profiles' for more information on page 6-26.

Some vehicles can exhibit shock due to the rapid reversal of torque after a direction change. 2909<sub>h</sub> can be set to force the vehicle to remain stationary for a period before driving in the new direction.

To prevent early exit from neutral braking, a debounce timer can be set at 290D<sub>h</sub>. Neutral braking only finishes when the vehicle has been stopped for longer than this time. This can help prevent early exit of neutral braking due to motor oscillation caused by under damped suspension.

On vehicles with gearbox meshing issues, a slower rate of torque ramp up at low speeds can be configured at 291C<sub>h</sub>. This slow rate of change of torque lessens shock due to gear meshing. Used in torque mode only.

Brake feathering reduces neutral and foot braking torques as the vehicle speed approaches 0 to prevent any roll-back in the opposite direction. This is set at 290E<sub>h</sub>. Use 290E<sub>h</sub>, 1+2 to set start and end speeds for feathering, 290E<sub>h</sub>, 3 to configure the final torque at the end of braking and 290E<sub>h</sub>, 4+5 to configure entry and exit ramp rates for feathering torque to prevent disturbance in torque when changing between drive and braking conditions. Used in torque mode only.

## Footbrake

The controller can use a switch or analogue voltage as the footbrake input. If a footbrake switch is mapped, it applies maximum foot braking when the switch is closed. The footbrake switch object (2130<sub>h</sub>) must be mapped to a digital input.

If the footbrake input is an analogue voltage, configure the voltage levels in the same way as the throttle. The footbrake voltage (2221<sub>h</sub>) must be mapped to an analogue input.

Configure the characteristics of the footbrake at 2911<sub>h</sub>:

- Drive/foot braking priority. If the throttle and footbrake are pressed at the same time, this setting determines whether the system attempts to drive or brake.
- Minimum speed for braking. Foot braking stops when the vehicle speed drops below this level.
- Footbrake voltage input and Input characteristic. These settings are similar to those for the throttle. Refer to the Throttle section above for more information.
- Footbrake priority timeout allows the configured priority to change after a timeout period. Setting zero will disable this feature.

The footbrake value calculated from the voltage can be read at 2621<sub>h</sub>.

## Steering inputs – twin driving motor systems



---

**CAUTION:** Loss of steering information can make a vehicle operate erratically. The analogue input use for the steering sensor should have suitable wire-off protection configured.

---

Twin motor systems, which use the drive motors for turning, require some means of determining the angle of the steering wheel.

To do this use one of these options:

- A steering potentiometer to give an analogue voltage which is a linear function of the steering angle. The steer potentiometer voltage (2223<sub>h</sub>) must be mapped to an analogue input.
- Four digital inputs representing 'inner left', 'inner right', 'outer left' and 'outer right'. The inner switches indicate the steering angle where torque to the inner wheel motor is removed. The outer switches indicate the steering angle where inner wheel motor changes direction. The

outer switches are optional. The steer switches (212B<sub>h</sub> to 212E<sub>h</sub>) must be mapped to digital inputs.

- Steering angle from 3<sup>rd</sup> party CAN device. This can be received via RPDO on object 2624<sub>h</sub> in 0.01°/bit resolution.

To configure steering inputs go to index 2913<sub>h</sub> in the Object Dictionary:

- Setup the voltages corresponding to fully left, fully right and straight ahead. Using this information, Gen4 calculates the steering angle based on the voltage from a steering potentiometer.
- Setup the steering map. This map defines the relationship between the inner and outer wheel speeds and the steering angle. Each map has 4 user definable points as shown in Figure 28.

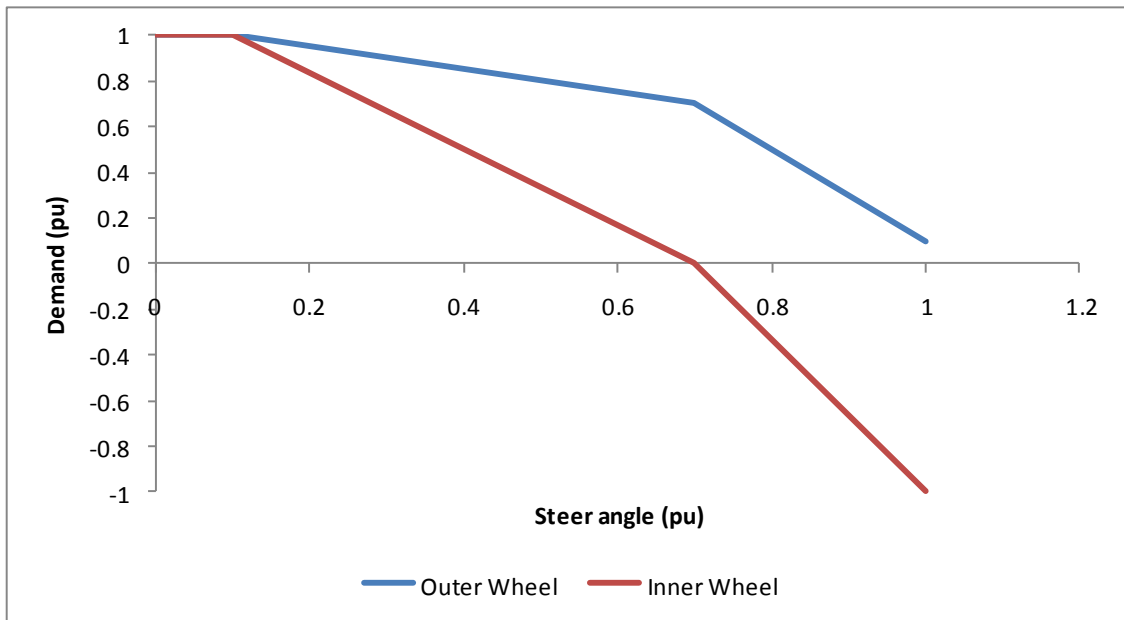

Figure 28 Graph of speed vs. steering angle

The speed and steering angle are normalized. Speed is normalized to maximum vehicle speed and the steering angle to 90°.

In speed mode, outer wheel speed target and maximum torque is scaled according the outer wheel map. Inner wheel speed target and maximum torque is scaled to the outer wheel demands according to the inner wheel map.

In torque mode, both inner and outer wheel maximum speeds are scaled according the outer wheel map. The outer wheel target torque comes from the throttle. The inner wheel target torque is scaled to the outer wheel actual torque according the inner wheel map.

In object 2913<sub>h</sub>, 0 to 1 is represented by values in the range 0 to 32767. The inner wheel is scaled according to the outer wheel. Where a demand (pu) of -1 is shown at 90° for the inner wheel, this means the inner wheel demand will be equal and opposite to the outer wheel.

The calculated steering angle can be read at 2623<sub>h</sub>. An angle value of -32767 indicates full steering to the left, +32767 full steering to the right and 0 is straight ahead.

If steering switches are used instead of a steering potentiometer, only part of the steering map is used as shown in Table 6.

Value	Description
2913 <sub>h</sub> ,9	Outer wheel speed during inner wheel cutback
2913 <sub>h</sub> ,11	Outer wheel speed during inner wheel reversal
2913 <sub>h</sub> ,17	Inner wheel cutback speed
2913 <sub>h</sub> ,19	Inner wheel reverse speed

Table 6 Objects to set when using steering switches



**NOTE:** During a turn the inner wheel speed is slowed by power reduction instead of braking to prevent the outer wheel motor working against the inner wheel motor.

## Driveability profiles



**WARNING:** Ensure driveability profiles are disabled when not required. Activation of a driveability profile can cause driving parameters to change.

Driveability profiles allow you to set maximum values for speed, torque, acceleration and deceleration for use in a range of operational situations. In addition, in torque mode, there are ramp rates for speed limits as well. and Figure 30 show the change in speed and torque target under various driving conditions over a period of time.

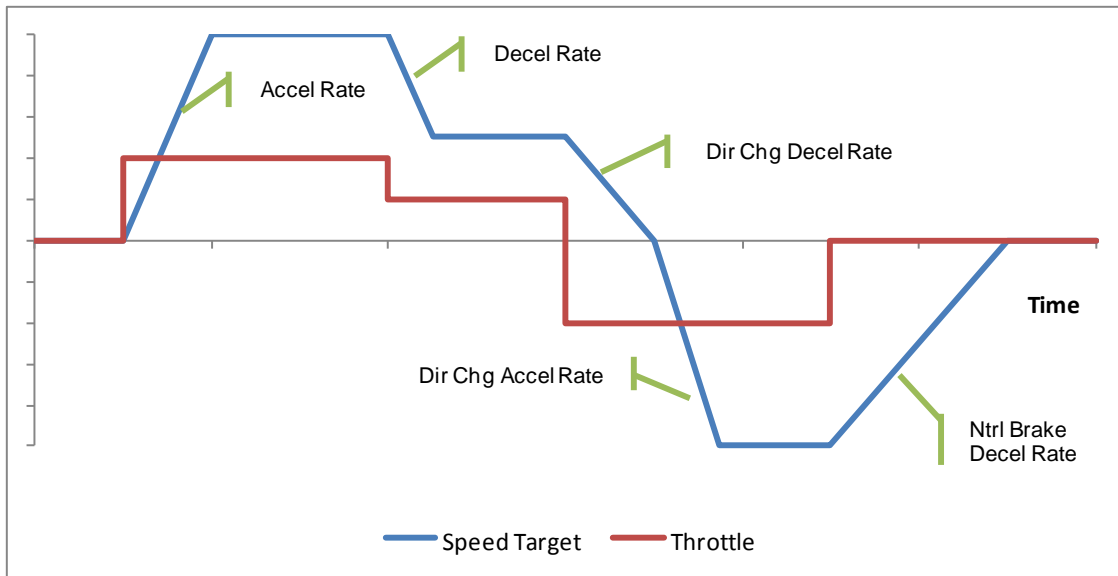

Figure 29 Speed mode acceleration/deceleration



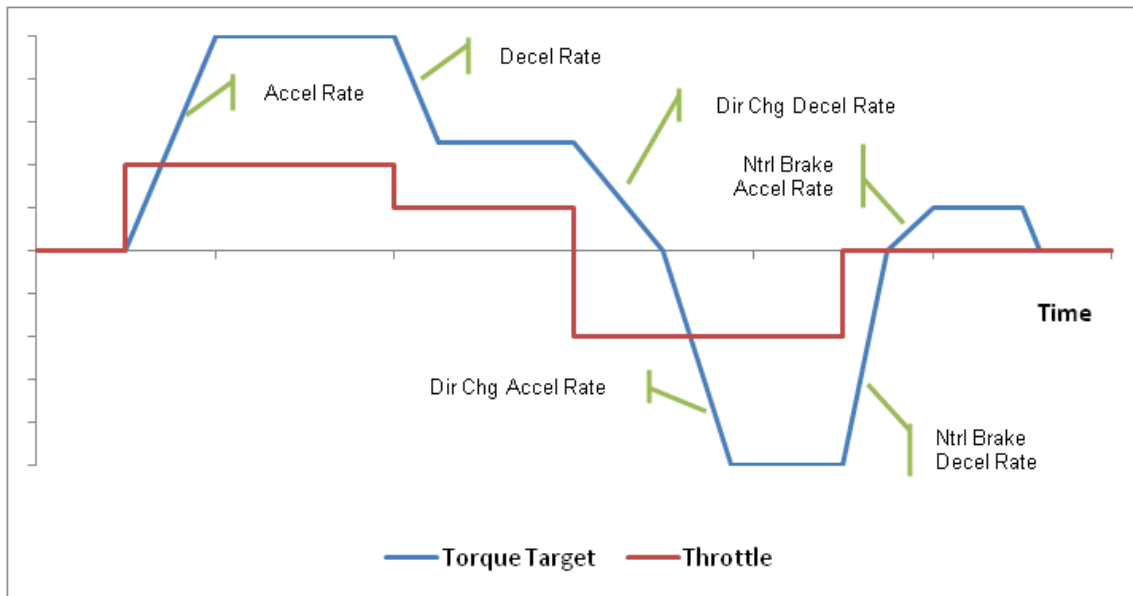

Figure 30 Torque mode acceleration/deceleration

In Torque mode, the acceleration and deceleration rates control the rate of change of torque. In Speed mode, the acceleration and deceleration rates control the rate of change of speed.

You can select reverse while driving in the forward direction with your foot still on the throttle. In this situation the controller applies braking in the form of a direction change deceleration rate down to zero speed. It then applies a direction change acceleration rate to increase the vehicle's speed in the reverse direction up to the set maximum speed as shown above.

Configure the following drivability profiles to suit your application (each containing the same set of parameters):

- Traction baseline profile: the default and highest set of values (2920<sub>n</sub>).
- Drivability select 1 profile: invoked when drivability select 1 switch is active (2921<sub>n</sub>) or an alternative trigger is active (see below).
- Drivability select 2 profile: invoked when drivability select 2 switch is active (2922<sub>n</sub>) or an alternative trigger is active (see below).

The traction baseline profile contains the default maximum values. All of the remaining profiles apply lower, modifying values to the baseline profile. BDI and service profiles, when configured, are automatically applied by the software under preset conditions. For example you may want to limit the acceleration and maximum speed of a vehicle when the battery gets low to maximize the operating time before recharge. The remaining profiles are applied by the driver with a switch.

Drivability profiles can also be invoked by internal software triggers, such as BDI low, service required or low speed. These can be selected to suit specific application requirements. Set the profile triggers in 2931<sub>n</sub>.



**NOTE:** Where more than one profile is active, the lowest value(s) are used by the software.

Speeds in drivability profiles are scaled according to the vehicle gear ratio (2915<sub>n</sub>). This is used to convert speed in RPM to any other preferred unit such as KPH or MPH. To remove this scaling and leave drivability profile speeds in RPM, set 2915<sub>n,3</sub> to 1.

Torques in driveability profiles are in 0.1%/bit resolution. These are converted to Nm using the motor rated torque value at object 6076<sub>h</sub>.

Ramp rates in driveability profiles are in either RPM/s for speed mode, or %/s for torque mode. In speed mode, RPM/s becomes “User Defined Units” / s if the gear ratio is used to rescale the driveability profile speeds.

Speed limit ramp rates are only used in torque mode and are in RPM/s (or user defined units / s).



**WARNING:** In addition to the speed limit ramp rates in the profiles, 291E<sub>h</sub> can be used to configure safety limits on speed limit ramping. The installer should set these ramp rates to suitable levels to ensure speed limits cannot ramp faster than could actually happen on a vehicle. This can protect against harsh braking if traction wheels are momentarily locked.

## Smoothing Output Torque

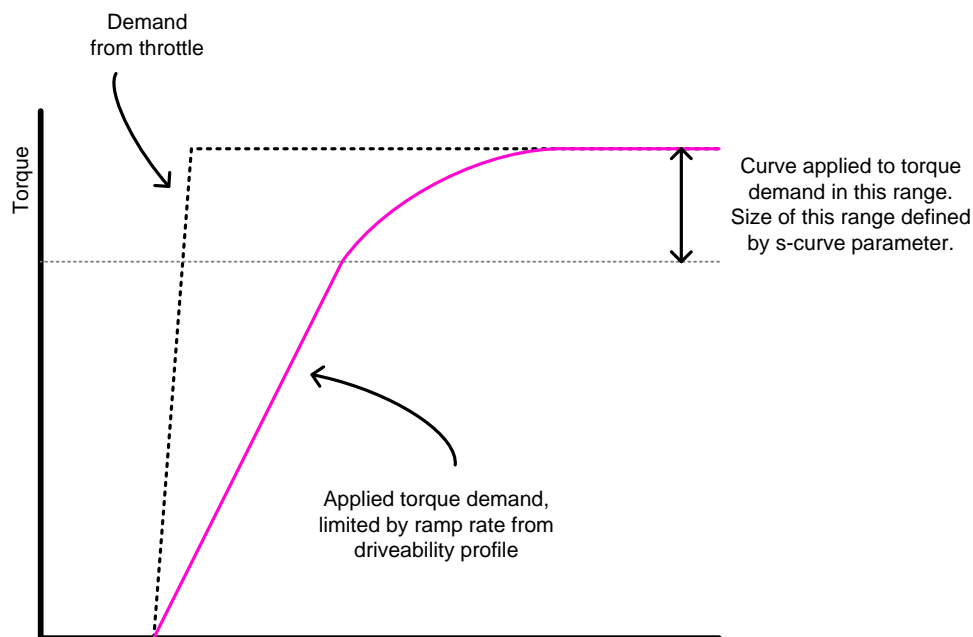

Figure 31 - Illustration of s-curve on torque demand

The controller provides an option to insert an s-curve to the torque demand as it approaches the value requested by the throttle. This curve feature can serve two purposes:

The amount of curve applied can be configured in the object dictionary at index 2933<sub>h</sub>. Generally, applying a greater curve range will result in smoother drive, but too much can lower vehicle response. S-curve is applied according to this table:

Value in 2933 <sub>h</sub>	S-curve behavior
0	None applied
1	Curve applied within 0.2% of target

2	Curve applied within 0.4% of target
3	Curve applied within 0.8% of target
4	Curve applied within 1.6% of target
5	Curve applied within 3.2% of target

This table continues, with each increment in 2933<sub>h</sub> doubling the range over which the curve is applied.

## Preventing Wheel Lock Scenarios

For certain vehicle types, particularly on-highway vehicles or electric motorcycles, the possibility of wheel locking during drive must be considered.

During braking, the controller will maintain a speed limit to ensure the vehicle does not over speed if entering braking whilst travelling downhill. If proportional speed limit is set then the speed limit will follow actual speed toward zero whenever actual speed is dropping rapidly, usually due to some external influence such as application of mechanical brakes.

If the brakes are applied too harshly, then there is possibility to lock the drive wheels. In these circumstances, the normal reaction of the driver is to release the brake to allow the wheels to rotate again. The correct operation of the controller in this scenario is to allow the wheels to continue to rotate, and not impose a speed limit.

The maximum rate at which the speed limit can increase or decrease is specified in object 291E<sub>h</sub>. By limiting the rate at which the speed limit can decrease, we can ensure that if the brakes are released after they had locked the drive wheels, the controller's speed limit will allow them to rotate again. The operation of this is shown in Figure 32 below.

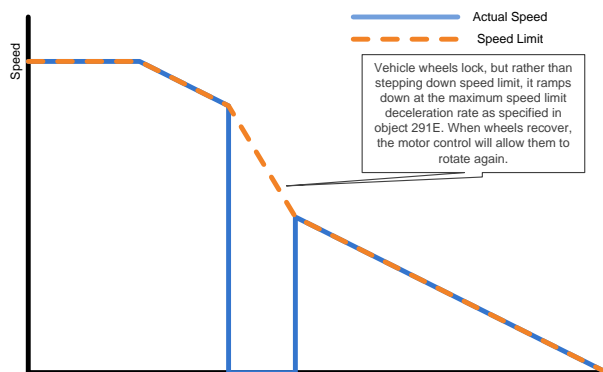

Figure 32 - Example of behaviour of speed limit when drive wheels are locked



**WARNING:** It is important to consider the behaviour of the vehicle under all drive conditions, including when traction is lost due to locking of the drive wheels. When testing a vehicle, check that the vehicle behaves in a safe manner when performing harsh braking on low-friction surfaces such as gravel.

## Controlled roll-off

---



**WARNING: Controlled Roll-Off is not recommended for on-highway vehicles as it can cause the traction motor/wheel to remain locked or brake severely if the wheel is momentarily locked due to loss of traction on a slippery surface and/or mechanical braking.**

---

Controlled roll-off limits a vehicle to a slow, safe speed if it starts to move without any operator input. Primarily, it is to prevent uncontrolled movement if a vehicle's brakes fail on an incline. Controlled roll-off operates whether the operator is present or not.

Configure the following at object 2930<sub>h</sub>:

- Enable/disable controlled roll-off
- Set a roll-off maximum speed
- Set a roll-off maximum torque

Alternatively, Gen4 can apply an electromagnetic brake if one is mapped and roll-off is detected. Refer to 'Electro-mechanical brake' on page 6-34 for more information.

## Hill hold

---



**WARNING: Hill Hold is not recommended for on-highway vehicles as it can cause the traction motor/wheel to remain locked or brake severely if the wheel is momentarily locked due to loss of traction on a slippery surface and/or mechanical braking.**

---

A vehicle on a hill can be held at a standstill for a configurable time when the operator selects neutral. At the end of this time or if the seat switch indicates the operator is not present, hill hold terminates and the vehicle can start to move if parked on an incline. If enabled, the system will enter controlled roll-off after hill hold.

You can set the hill hold delay at object 2901<sub>h</sub>. Set the hill hold delay to 0 to disable this feature.

In speed mode, drive torque is disabled whilst neutral braking to stop. However, drive torque must be re-enabled when entering Hill Hold to allow torque to be applied to hold on the incline. Set the speed to re-enable drive torque at 2908<sub>h</sub>.

## Inching

---



**WARNING: Ensure inch switches are only mapped to digital inputs when required. Activation of these inputs can cause a drive condition to occur.**

---

Inching allows an operator to manoeuvre a vehicle, at low speeds, towards a load. Inching can be initiated with one switch. A time-out is used to prevent the vehicle from continuing to drive indefinitely if the switch gets stuck or goes short circuit.

To configure inching:

- Ensure forward and reverse inching switches have been mapped to two digital inputs.
- Specify an inching speed (0% to 25% of the full speed of the vehicle) at 2905<sub>h</sub> sub-index 1. This is either a speed target in speed mode, or maximum speed in torque mode.
- Specify an inching throttle (0 to 100%) at 2905<sub>h</sub> sub-index 3. This gives a torque target in torque mode. This is not used in speed mode.
- Specify a time-out (0.1 s to 5.0 s) at 2905<sub>h</sub> sub-index 2.

## Belly Switch



---

**WARNING: Ensure the belly switch is only mapped to a digital input when required. Activation of this input can cause a drive condition to occur.**

---

The belly switch is normally connected to the end of the tiller arm on class 3 vehicles. When activated it forces a drive condition in forward at a user specified throttle value and maximum speed for a specified time.

To configure belly:

- Ensure the belly switch is mapped to a digital input.
- Specify the maximum belly speed at 290C<sub>h</sub> sub-index 2.
- Specify a belly throttle at 290C<sub>h</sub> sub-index 1. This will determine the torque demand in torque mode or speed demand in speed mode.
- Specify a belly time out at 290C<sub>h</sub> sub-index 3. The belly function will cease after this time has expired.

## Drivability select switches



---

**WARNING: Ensure the drivability switches are only mapped to digital inputs when required. Activation of these inputs can cause driving parameters to change.**

---

There are two drivability select switches (2126<sub>h</sub> and 2127<sub>h</sub>).

To enable either of these they must be mapped to digital inputs. When they are active, the corresponding drivability profiles (2921<sub>h</sub> and 2922<sub>h</sub>) are applied.

See Drivability profiles (page 6-26) for more information.

## Economy

The economy input is an analogue input which can be used to increase vehicle efficiency and extend battery life. It is normally controlled using a potentiometer mounted on the vehicle's dashboard. The economy voltage (2222<sub>h</sub>) must be mapped to an analogue input.

Efficiency is improved by reducing the acceleration rate or the maximum torque.

Configure the economy input at object 2912<sub>h</sub> as follows:

- Economy function: select acceleration or torque.
- Economy voltage input: These settings are similar to those for the throttle (see page 6-20).

The economy value calculated from the voltage can be read at 2622<sub>h</sub>.

## Pump configuration

The controller can use a mixture of switch and analogue voltages as the pump input. In addition, the power steer function can be used as an extra input to the pump if the pump motor is required to supply pump and power steering.



---

**NOTE: Pump motors always run in speed mode. Ensure the motor slave is also configured for speed mode in 6060<sub>h</sub>.**

---

## General Setup

Configure the pump features at 2A00<sub>h</sub>:

- Inhibit pump when BDI drops below cut-out level. If already operating when the cut-out occurs, the pump will continue to operate until all pump inputs are inactive.
- Drive Enable switch and/or Seat switch input disables pump.
- Ignore Line Contactor state. Allows the pump to operate if it is not connected to the battery through the line contactor. Should be set if the pump also supplies power steering and the power steer is required to operate when the line contactor is open.
- Use Power Steer target velocity as pump input, if pump also supplies power steering.
- Enable minimum pump speed. Enable this to force the pump to run at minimum speed (2A01<sub>h</sub>, 2) even when there is no trigger. Can be used to maintain minimum pump pressure.
- Pump to stop on Low Battery. Enable to force pump to stop immediately on low battery condition.
- Use power steer demand to minimum pump speed. Enable this to force the pump to use power steer demand as a minimum speed. Can be used to maintain minimum pump pressure for power steering.

Set the pump minimum and maximum speed, maximum torque, acceleration and deceleration at 2A01<sub>h</sub>. The pump speed is calculated as the value from the inputs multiplied by the maximum speed.

## Priority/additive inputs

Each pump input can be configured as a priority input or an additive input. When calculating the pump demand, the controller selects the demand from the highest priority active input, and then adds the demand from all the active additive inputs.

Configure priority/additive levels in 2A10<sub>h</sub> and 2A11<sub>h</sub>, and 2A20<sub>h</sub> to 2A26<sub>h</sub>.

## Pump throttles

There are 2 pump throttle inputs, which can be configured independently at 2A10<sub>h</sub> and 2A11<sub>h</sub>. The pump throttles allow proportional control of the pump speed.

Configure inputs as priority or additive and set the voltage levels in the same way as the traction throttle. The pump throttles must be mapped to analogue inputs.

## Pump switches

There are 7 pump switch inputs. Configure each input as priority or additive and assign it a value at 2A20<sub>h</sub> to 2A26<sub>h</sub>. The pump switches must be mapped to digital inputs.

## Pump Driveability Profiles

Pumps have configurable driveability profiles. Profiles are triggered by pump driveability select switches (2152<sub>h</sub> and 2153<sub>h</sub>). One or more of these switches must be mapped to enable pump profiles.

Each profile allows the installer to reduce acceleration and deceleration rates, throttle and switch values and maximum torque.

Set pump driveability profiles at 2A30<sub>h</sub> and 2A31<sub>h</sub>

## Power steer configuration

### General

Power steering can be provided using:

- Contactor. Map the power steer contactor drive object to an analogue output.
- Pump motor controller. Configure pump to provide power steering. Power steer demand is added to pump demand.
- Dedicated motor controller. Map power steer application motor object to motor control slave.



---

*NOTE: Power steer motors always run in speed mode. Ensure the motor slave is also configured for speed mode in 6060<sub>h</sub>.*

---

- 

The power steer can be triggered by a number of events:

- Vehicle moving
- FS1 switch activating
- Direction selected.
- Seat switch activating
- Footbrake activating



---

**CAUTION:** The power steering function will always attempt to execute, even if the line contactor is open due to a fault condition. This is to ensure power steering continues to operate at all times.

---

Set the power steer motor speed, acceleration and deceleration at 2B01<sub>h</sub>. This is not required if the power steer motor is operated by a contactor.

### Variable Assist Power Steering

Gen4 supports a variable assist power steering algorithm which can be used to reduce the power steering speed as vehicle traction speed increases to a user configurable level. Set the reduction factor and traction speed in 2B02<sub>h</sub>. This allows power steering effort to be reduced as vehicle speed increases to prevent steering becoming too light.

# Vehicle features and functions

Ensure you have completed the CANopen network setup, Motor Characterization, I/O Configuration and Vehicle Performance Configuration processes described above.

## Contactors

Ensure voltage control has been selected (see 'Analogue' on page 6-15).

To configure any contactor:

- Set pull-in voltage, pull-in time and hold-in voltage at 2D00<sub>h</sub>
- Enable each output to operate at the pull-in voltage or at the maximum voltage at 2D01<sub>h</sub>
- If required enable each output to reduce to the hold voltage level at 2D02<sub>h</sub>

## Line contactor

The line contactor object (2400<sub>h</sub>) must be mapped to an analogue output.

The line contactor is used to isolate controllers and motors from the battery during power down or in case of a serious fault. It is normally closed all the time the vehicle is powered, but it can be configured to open when the vehicle has been stationary for a period of time.

Configure line contactor dropout at object 2820<sub>h</sub>. See also 'Contactors' above.

The controller has a capacitor pre-charge feature used to protect line contactor tips from damage due to in-rush currents when the contactor closes.



---

*NOTE: Writing to 5180<sub>h</sub> starts a pre-charge cycle. The pre-charge circuit can only supply enough current to charge the capacitors of one controller. Where more than one controller is present, the pre-charge circuit on each must be used. If an Gen4 is configured as the vehicle master, it controls the pre-charge of all slave nodes automatically.*

---

The pre-charge level is configurable between 50% and 90%. The level can be adjusted by object 5820<sub>h</sub>.

The minimum capacitor voltage allowed for the line contactor to close is set in 5821<sub>h</sub>.

## Electro-mechanical brake



---

**WARNING: Electro-mechanical brakes are not recommended for on-highway vehicles as they can cause the traction motor/wheel to remain locked or brake severely if the wheel is momentarily locked due to loss of traction on a slippery surface and/or mechanical braking. Also, electro-mechanical brakes normally fail to the applied state, meaning any loss of power, or wiring fault can cause the brakes to be applied.**

---

The electro-mechanical brake object (2420<sub>h</sub>) must be mapped to an analogue output.

Set the conditions under which it is applied at 2903<sub>h</sub>.

The brake can be applied when the vehicle stops or when roll-off is detected. If the brake is configured to apply when the vehicle stops, it is not applied until the vehicle has been stationary for more than the brake delay time.



To prevent vehicle roll away on inclines, the electro-mechanical brake normally does not release until the traction motor(s) are producing torque. This feature can be disabled using 2903<sub>n,3</sub>.

## External LED

This mirrors the operation of the controller's on board diagnostic LED. The external LED object 2401<sub>h</sub> can be mapped to an analogue output to drive a lamp on a vehicle dashboard.

## Alarm buzzer

The alarm buzzer object (2402<sub>h</sub>) must be mapped to an analogue output.

Configure the alarm buzzer output, if required, to be activated by one or more of these conditions at 2840<sub>h</sub>:

- forward motion or forward direction selected
- reverse motion or reverse direction selected
- faults other than information faults
- controlled roll-off
- BDI low.

A different cadence for each of the above conditions can be configured.

## Brake Lights

A brake light output object is available (2404<sub>h</sub>) and can be mapped to an analogue output. The brake lights will illuminate whenever the footbrake is pressed (providing either an analogue or digital footbrake input is available) or the system is in direction change braking.

## Horn

Ensure a digital input switch is mapped to the horn switch object (2101<sub>n</sub>) and an analogue output is mapped to the horn object (2403<sub>h</sub>).

## Vehicle Speed Calculation

The controller can be configured to calculate vehicle speed from motor speed by setting a configurable ratio between these values in object 2915<sub>h</sub>. Calculated vehicle speed can then be transmitted to the CANbus for use with compatible displays, or used to keep a log of total distance travelled by the vehicle.

The convention is to calculate vehicle speed as a signed number in 12.4 format in kph. This is required for compatibility with ClearView displays and the odometer. In case a custom display is used whose units are different, a user speed calculation is also provided whose units are independent from all other features.

Two sets of ratios are provided for calculation of a vehicle and user speeds, located in object 0x2915. While vehicle speed is a signed value, the option to have unsigned user speeds is also provided (an absolute value will be calculated).

The ratio between motor speed and vehicle speed will be dependent on vehicle drive train parameters such as gearbox ratio and wheel size. However, the ratio should be calculated such that when it is multiplied by motor speed (which is in rpm), the result is vehicle speed in kph 12.4 format. To do this, the following equation can be used:

- Set the divisor (object 2915<sub>h</sub> sub index 2) to a known speed point of the motor

- Set the multiplier (object 2915<sub>h</sub> sub index 1) to the corresponding scaled vehicle speed for the known motor speed.

For example, if it is known that 1000rpm on the motor results in a vehicle speed of 5kph, then the divisor should be set to 1000, and the multiplier should be set to 0x0050, which is 5kph in 12.4 format.

The same process should be repeated for the user speed ratio, setting the multiplier for the user speed in the desired custom format. Both the vehicle and user speeds, objects 0x2921 and 0x2922, can be mapped to TPDO for transmission to other devices via CAN if required.

## Distance Calculation

Total vehicle distance and trip distance counters are available at objects 0x29A0 and 0x29A1. Counters will operate and will be accurate provided that the vehicle speed calculated at object 0x2721 is in kph in 12.4 format. Counters are available in the following formats:

- Distance travelled in km in 24.8 format
- Distance travelled in km in 0.1km/bit increments
- Distance travelled in miles in 0.1mile/bit increments

Both distance counters objects can be mapped to TPDOs for monitoring over the CANbus, or for use by a dashboard display. The trip distance counter can be reset by holding the reset switch, object 0x217D, closed for 1 second. The total vehicle distance counter cannot be reset by the user.

## Service Indication

The controller can reduce vehicle performance and indicate to the operator when a vehicle service is required. The interval between services is user-configurable.

Configure the following at object 2850<sub>h</sub>:

- Service indication: via an analogue (contactor) output (e.g. to drive a dashboard lamp) and/or Gen4's LED.
- Source hours counter: selects the hours counter and is used to determine when a service is required.
- Service interval: hours between vehicle services. Can be used by the reset function (see below) or for information only.
- Next service due: Servicing is required when the source-hours counter reaches this time. This can be set manually, or automatically using the reset function; see below.
- Reset function: write to the reset sub-index at 2850<sub>h</sub> to automatically reset the service timer for the next service. The next service due time is calculated as the source hours counter time plus the service interval.

## Service profile

This is a drivability profile where you can set maximum torques, speeds and acceleration rates to be applied when a vehicle needs servicing (2925<sub>h</sub>). See 'Driveability profiles' on page 6-26.

## Traction motor cooling fan

This object can be used to drive a motor cooling fan when the operator is present on the vehicle (as indicated by the seat switch). The cooling fan object (2421<sub>h</sub>) must be mapped to an analogue output.

## Controller heatsink / motor cooling fan

An external fan to cool the controller heatsink or a motor may be connected to one of the analogue outputs. The fan will be turned on by the controller when either the heatsink temperature or the motor temperature exceed a specified temperature. The fan turns off when the nominated temperature is cold. The temperatures at which the fans should turn on and off, the analogue output to use for the fan, the fan voltage and the temperature source (heatsink or motor) can be programmed using the heatsink fan object (5A01<sub>h</sub>). Note that the contactor driver outputs may be damaged if connected to capacitive loads. It is quite common for fans to incorporate capacitive elements, in which case a relay should be used to isolate the fan from the contactor driver output.



---

**NOTE:** *The temperature set-point to turn on the fans should be higher than the set-point to turn off the fans*

*The fans will not operate if another function is configured to run on the specified analogue output.*

---

## Motor over-temperature protection

The controller protects motors from over-temperature. It maintains a motor temperature estimate and can also accept a direct temperature measurement via an analogue input (for a thermistor) or a digital input (for an over-temperature switch).

The temperature estimate is calculated by monitoring current to the motor over time. The estimate is configured at 4621<sub>h</sub>.

The estimate is always applied, since it can detect increases in motor temperature more quickly than the direct measurement. Direct measurement is normally done on the motor casing, which lags behind the internal temperature.

Additional protection is provided for thermistor wire-off conditions. If the temperature sensor input measures a completely short circuit or open circuit signal, then the output torque will begin to reduce gradually over time. A recovery rate can also be specified should the signal become valid again. This means that wire-off situations, should they occur during drive, do not result in an instant loss of torque. Both the torque ramp down and recovery rates can be configured using object 4620<sub>h</sub>.

## Motor over-speed protection

A facility to protect the motor or vehicle power train due to damage by overspeeding is available on the controller. A maximum speed can be configured at object 4624<sub>h</sub>. Under normal operation the controller should output braking torque to prevent the overspeeding initially, if the measured speed exceeds this limit then the controller will shut down and a fault will be set.



---

**CAUTION:** *The trip speed offers a final level of protection for the vehicle mechanics, and should be set to a minimum level that would not be expected to be reached under normal operation.*

---

## Battery protection

The nominal battery voltage must be set at 2C00<sub>h</sub>.

### Over voltage

Battery over voltage usually occurs during regenerative braking.

To provide protection set values for these parameters at 2C01<sub>h</sub>:

- Over voltage start cutback: the value at which the braking effort is linearly reduced to limit voltage increase.
- Over voltage limit: the value at which the controller cut-outs out. A fault is set if the voltage exceeds the cut-out voltage.

## Under voltage

To prevent excessive battery discharge, set values for these parameters at 2C02<sub>h</sub>:

- Under voltage start cutback: the value at which the current drawn from the battery is reduced to limit voltage decrease.
- Under voltage limit: the value at which the controller cut-outs out. A fault is set if the voltage drops below the cut-out voltage for longer than the protection delay
- Protection delay: the time it takes for the controller to cut-out after the under voltage limit has been reached (2C03<sub>h</sub>).

## Battery Discharge Indicator (BDI)

Monitor battery voltage using Gen4's Battery Discharge Indicator (BDI). The BDI presents the driver with a percentage remaining charge figure and has become an industry standard in recent years.



---

*NOTE: The BDI is not a measure of the absolute battery charge remaining and therefore we recommend you regularly check the absolute value in accordance with the battery manufacturer's instructions.*

---

To use the BDI, configure the following parameters at 2C30<sub>h</sub> in the Object Dictionary:

- Cell count: this is the number of battery cells and is normally half the battery voltage, as cells are usually 2 volts each.
- Reset voltage (V): set this to the cell voltage when the batteries have just been charged. This resets the BDI back to 100%.
- Discharge voltage (V): set this to the cell voltage when the battery is discharged.
- Cut-out level (%): this is the level at which the vehicle adopts the low battery drivability profile.
- Discharge rate (s/%): this is the rate at which the BDI remaining charge value discharges. Set to 0 to use default value of 16.8s to reduce by 1%. This default should suit most lead-acid battery types, however, this can be increased/decreased for different battery technologies.



---

*NOTE: Setting the warning and cut-out levels to 0% disables the warning and cut-out functionality*

---

An additional table exists at index 2C31<sub>h</sub> which allows an initial BDI value to be specified at start up based on the measured battery voltage. At start up, the measured battery voltage is taken, and the corresponding BDI percentage remaining value is then used as the starting point for the BDI. After this, the BDI remaining value operates in the standard way. Note, this function is only available if the corresponding bit is set in object 2C30<sub>h</sub> sub 1.

Read the percentage remaining charge value from 2790<sub>h</sub> sub-index 1 in the Object Dictionary.

## Battery Current Limit

Battery current can be limited by the controller for the purposes of efficiency or to protect batteries that are sensitive to high levels of current flow. Charge and discharge currents can be limited independently.

If limiting the discharge current flow, this can extend the time taken for the vehicle to reach top speed. Note that limiting the charge current flow back to the battery can impede the performance of regenerative braking.

Object 2870<sub>h</sub> controls how the battery current limit is calculated. Sub-index 1 of this object can be set to one of the following values to specify how the current limit behaves:

Value	Mode
0x00	Master control of battery current limit disabled. To completely disable battery current limit, object 4623 <sub>h</sub> sub index 3 must also be set to 0x0000.
0x01	Battery current limit set by object 4623 <sub>h</sub> sub index 2 and 3.
0x02	Battery current limit controlled by compatible BMS
0x03	Battery current limit set by object 4623 <sub>h</sub> sub index 2 and 3, but the drive current limit is multiplied down by factors set in sub index 4 and 5 when driveability profiles are activated
0x04	Battery current limit is calculated to maintain a power limit as set in sub index 6 and 7.

Object 2871<sub>h</sub> provides a means to have TracApp cut back the torque demand in situations where the battery current limit is reduced. This is useful for configurations where an external BMS can cut back the current limits to low levels. Effectively, it prevents TracApp requesting torque that cannot be achieved.

Object 4623<sub>h</sub> shows the current limits that are in effect. Sub index 3 of this object allows you to specify the cutback aggressiveness and a measurement correction factor. Setting this to zero. Battery current flow can be monitored at object 5100<sub>h</sub>.

Note that regen currents flowing back to the battery are specified as negative numbers.

## Displays

Gen4 is compatible with Smartview and Clearview displays.

Clearview displays use the CANopen protocol. To use, set up TPDOs to transmit the required data for the display.

Smartview displays use Sevcon's proprietary CAN protocol. To use set the CAN baudrate to 100kHz at 5900<sub>h</sub>, enable Smartview and select hours counter and/or real speed at 2E00<sub>h</sub>.





## Chapter 7: Monitoring Gen4

# Reading status variables

All status variables are in Gen4's object dictionary. They can be accessed using SDOs. Some can be mapped to PDOs for continuous transmission to remote nodes such as displays and logging devices.

## Motor measurements

The following status objects can be read:

- Motor slip frequency, currents, voltages and temperature at object 4600<sub>h</sub>.
- Additional motor debug information is available at 4602<sub>h</sub>.
- Motor torque, speed, etc. at objects 6000<sub>h</sub> to 67FF<sub>h</sub>.

## Heatsink temperature

Read the heatsink temperature at object 5100<sub>h</sub>, sub-index 3.

## Identification and version

Read identification and version information at:

- 1008<sub>h</sub> – Controller name.
- 1009<sub>h</sub> – Hardware version.
- 100A<sub>h</sub> – Software version.
- 1018<sub>h</sub> – Identity object. Contains CANopen vendor ID, product code, CANopen protocol revision, and controller serial number.
- 5500<sub>h</sub> – NVM (EEPROM) format.
- 5501<sub>h</sub> – Internal ROM checksum.

## Battery monitoring

The controller measures actual battery voltage at two points:

- Battery voltage; measured at keyswitch input and read at 5100<sub>h</sub> sub-index 1.
- Capacitor voltage; measured at the B+ terminal and read at 5100<sub>h</sub> sub-index 2.

The controller also has a battery discharge indicator (BDI), which can be read at 2790<sub>h</sub>.



## Hours counters

The controller supports many different hours counters for various functions. Some counters run on all units and some only run on the Gen4 configured as the vehicle master.



---

*Hours counters are preserved with a minimum resolution of 15 seconds when the system is powered down.*

---

### Local hours counters

Local hours counters which run on all units are:

- Controller key hours: increments while the keyswitch is in the ON position (5200<sub>h</sub>).
- Controller pulsing hours: increments when the controller is powering its connected motor (4601<sub>h</sub>).

### Vehicle hours counters

Vehicle hours counters which run only on the Gen4 configured as the vehicle master are:

- Vehicle key hours: increments as controller key hours (2781<sub>h</sub>).
- Vehicle traction hours: increments when the vehicle is driving or braking (2782<sub>h</sub>).
- Vehicle pump hours: increments when the pump motor is running (2783<sub>h</sub>).
- Vehicle power steer hours: increments when the power steer motor is running (2784<sub>h</sub>).
- Vehicle work hours: increments when the traction, pump or power steer motors are running (2785<sub>h</sub>).

Since these hours are specific to the vehicle, they are writeable so that they can be reset to known good values if the master controller is replaced.

## Logging

The controller can log events in the system (along with additional event-related information) and minimum and maximum levels of important parameters. You need different levels of access to clear the contents of the logs.

Logs are normally reset individually. However, to reset all logs at once write to 4000<sub>h</sub>.

### FIFO event logs

Events are recorded by these two separate FIFOs (first in, first out logs), which operate identically:

- System: this FIFO is 20 elements deep and is used for events such as software upgrades, user logins and some hardware upgrades (4100<sub>h</sub> to 4102<sub>h</sub>).
- Faults: this FIFO is 40 elements deep and is used for fault logging (4110<sub>h</sub> to 4112<sub>h</sub>).

At object 41X0<sub>h</sub>:

- Reset the FIFO
- Read its length

You can access the FIFO using objects 41X1<sub>h</sub> and 41X2<sub>h</sub>. The FIFO index is entered at 41X1<sub>h</sub> and the data is read from 41X2<sub>h</sub>.

## Event counters

The controller provides 10 event counters at 4200<sub>h</sub> to 420A<sub>h</sub>. Each event counter can record information about occurrences of one event. The allocation of event counters to events is user-configurable however Gen4 will automatically count important events in unused counters. The information recorded in each event counter is:

- The time of the first occurrence
- The time of the most recent occurrence
- The number of occurrences

## Operational monitoring

At objects 4300<sub>h</sub> and 4301<sub>h</sub>, Gen4 monitors and records the minimum and maximum values of these quantities:

- Battery voltage
- Capacitor voltage
- Motor current
- Motor speed
- Controller temperature

Two instances of the operational monitoring log are maintained. Service engineers can access and clear the first log; the second is accessible and clearable only by Sevcon engineers. The Customer copy is normally recorded and reset each time the vehicle is serviced. The Sevcon copy records data over the controller's entire working life.

## CANopen abort code

The controller will sometimes respond with a CANopen General Abort Error (08000000<sub>h</sub>) when the object dictionary is accessed. This can occur for many reasons. Object 5310<sub>h</sub> gives the exact abort reason. These are:

0	None	12	Invalid value	24	Cannot read from DSP
1	General	13	EEPROM write failed	25	Peek time out
2	Nothing to transmit	14	Unable to reset service time	26	Reserved for future use
3	Invalid service	15	Cannot reset log	27	Reserved for future use
4	Not in pre-operational	16	Cannot read log	28	Reserved for future use
5	Not in operational	17	Invalid store command	29	Reserved for future use
6	Cannot go to pre-operational	18	Bootloader failure	30	Reserved for future use
7	Cannot go to operational	19	DSP update failed	31	Reserved for future use

# Monitoring

8	Access level too low	20	GIO module error failed	32	Checksum calculation failed
9	Login failed	21	Backdoor write failed	33	PDO not copied
10	Range underflow	22	Reserved for future use		
11	Range overflow	23	Cannot write to DSP		

# Faults and warnings

## Introduction

In the event of a fault Gen4 takes the following action:

1. Protects the operator and vehicle where possible (e.g. inhibits drive).
2. Sends out an EMCY message on the CANbus.
3. Flashes the LED in a pattern determined by the fault type and severity.
4. Logs the fault for later retrieval.

## Fault identification

You can identify a fault as follows:

- Check the number of LED flashes and use below to determine what action can be taken. A complete and comprehensive fault identification table will be available from Sevcon in due course.
- Pick up the EMCY on the CANbus and read the fault condition using configuration software
- Interrogate the fault on the node directly using DVT or other configuration software.

## LED flashes

Use below to determine the type of fault from the number of LED flashes. The LED flashes a preset number of times in repetitive sequence (e.g. 3 flashes – off – 3 flashes – off – and so on). Only the faulty node in a multi-node system flashes its LED. Possible operator action is listed in the right hand column of the table.

LED flashes	Fault	Level	Set conditions	Operator action
0 (off)	Internal hardware failure	RTB	Hardware circuitry not operating.	
1	Configuration item out of range	VS	At least one configuration items is outside its allowable range.	Set configuration item to be in range. Use 5621 <sub>h</sub> to identify out of range object.
1	Corrupt configuration data	VS	Configuration data has been corrupted.	
1	Hardware incompatible with software or invalid calibration data	VS	Software version is incompatible with hardware. Calibration data for sensors invalid.	
2	Handbrake fault	I	Direction selected with handbrake switch active.	Release handbrake
2	Sequence fault	DI	Any drive switch active at power up.	Reset drive switches

# Monitoring

LED flashe s	Fault	Level	Set conditions	Operator action
2	SRO fault	DI	FS1 active for user configurable delay without a direction selected.	Deselect FS1 and select drive
2	FS1 recycle	DI	FS1 active after a direction change	Reset FS1
2	Seat fault	DI	Valid direction selected with operator not seated or operator is not seated for a user configurable time in drive.	Must be seated with switches inactive
2	Belly fault	DI	Set after belly function has activated.	
2	Inch sequence fault	DI	Inch switch active along with any drive switch active (excluding inch switches), seat switch indicating operator present or handbrake switch active.	
2	Invalid inch switches	DI	Inch forward and inch reverse switches active simultaneously.	Both inch switches inactive.
2	Two direction fault	DI	Both the forward and reverse switches have been active simultaneously for greater than 200 ms.	Reset switches
2	Invalid steer switch states	VS	Steering switches are in an invalid state, for example, both outer switches are active.	Check steer switches.
3	Fault in electronic power switching circuit	VS	Fault in electronic power switching circuit (e.g. MOSFET s/c).	
3	Hardware over voltage activated	VS	Hardware over voltage circuit activated	Investigate and reduce battery voltage below user defined maximum level. Ensure suitable over voltage is configured in 2C01 <sub>n</sub> and 4612 <sub>n</sub> .
3	Hardware over current trip activated	VS	Hardware over current circuit activated	Check motor load and wiring. Check motor parameters are correct.
4	Line contactor welded	S	Line contactor closed at power up or after coil is de-energized.	Check line contactor condition/wiring.

LED flashe s	Fault	Level	Set conditions	Operator action
4	Line contactor did not close	S	Line contactor did not close when coil is energized.	Check line contactor condition/wiring.
5	PST fault	DI	Fault detected on PST power steer module.	Check PST condition.
5	Motor open circuit	S	Unable to establish current in motor.	Check motor condition/wiring.
6	Throttle pressed at power up	DI	Throttle demand is greater than 20% at power up.	Reduce demand
6	Analogue input wire-off	VS	Analogue input voltage is outside allowable range.	Check analogue input wiring
6	Analogue output fault (over/under current, failsafe, short circuit driver)	VS	Analogue output fault caused by over current (>4A), under current if actual current < 50% target (current mode only), failsafe circuit fault, short circuit driver MOSFET.	Check analogue output wiring.
7	BDI warning or cut-out	I	BDI remaining charge is less than warning or cut-out levels.	Charge battery.
7	Battery low voltage protection	I	Battery voltage or capacitor voltage is below a user definable minimum battery level for a user definable time.	Increase battery voltage above user defined level
7	Controller low voltage protection	I	Battery voltage or capacitor voltage is below the minimum level allowed for the controller.	Increase battery voltage above minimum level
7	Controller high voltage protection with line contactor closed.	I	Battery voltage or capacitor voltage is above the maximum level allowed for the controller with line contactor closed.	Investigate and reduce battery voltage below maximum level.
7	Battery high voltage protection	I	Battery voltage or capacitor voltage is above a user definable maximum battery level for a user definable time.	Investigate and reduce battery voltage below user defined maximum level.
7	Motor low voltage protection	I	Capacitor voltage has entered the motor low voltage cutback region defined in 4612 <sub>h</sub> .	Increase battery voltage above start of motor low voltage cutback region.
7	Motor high voltage protection	I	Capacitor voltage has entered the motor high voltage cutback region defined in 4612 <sub>h</sub> .	Reduce battery voltage below start of motor high voltage cutback region.

# Monitoring

LED flashe s	Fault	Leve l	Set conditions	Operator action
7	Controller high voltage protection with line contactor open.	S	Battery voltage or capacitor voltage is above the maximum level allowed for the controller with line contactor open.	Isolate controller and investigate high battery voltage
7	Battery voltage below critical level for controller.	S	Battery voltage is below the absolute minimum voltage at which the controller hardware is guaranteed to operate.	Increase battery voltage.
7	Precharge failure	VS	Capacitor voltage is less than 5V after pre-charge operation is complete.	Check controller wiring to ensure there are no short circuits between B+ and B-.
8	Controller too hot	I	Controller has reduced power to motor(s) below maximum specified by user settings due to controller over temperature.	Remove loading to allow controller to cool down.
8	Controller too cold	I	Controller has reduced power to motor(s) below maximum specified by user settings due to controller under temperature.	Allow controller to warm up to normal operating temperature.
8	Motor over temperature	I	Controller has reduced power to motor(s) below maximum specified by user settings due to motor over temperature.	Reduce load to motor to allow it to cool down.
8	Motor too cold	I	Motor thermistor reports less than -30°C.	Allow motor to warm up. Check motor thermistor.
8	Heatsink over temperature	VS	Heatsink temperature measurement has exceed absolute maximum for controller and system has powered down.	Remove loading to allow controller to cool down.
10	Pre-Operational	I	Controller is in pre-operational state.	Use DVT to put controller into operational state.
10	I/O initializing	I	Controller has not received all configured RPDOs within 5s of power up.	Check CANbus wiring and PDO configuration.
10	RPDO Timeout	I / DI / S	One or more RPDOs have not been received within 3s at power up or within 500ms during operation.	Check CANbus wiring and PDO configuration.

LED flashe s	Fault	Level	Set conditions	Operator action
11	Encoder fault	VS	Speed measurement input wire-off is detected. Or encoder signals out of range or misaligned.	Check encoder wiring. Calibrate analogue encoder signals for sin/cos.
11	Over current	VS	Software has detected an over current condition	Check motor load and wiring. Check motor parameters are correct.
11	Current Control fault	VS	Software is unable to control currents on PMAC motor.	Check motor load and wiring. Check motor parameters are correct.
12	Communication error	S	Unrecoverable network communication error has been detected.	Check CANbus wiring and CANopen configuration.
13	Internal software or hardware fault	RTB	Software run time error captured or hardware variant not recognised.	
13	Current sensor auto-zero fault	RTB	Current sensor voltage out of range with no current.	
13	DSP parameter error	RTB	Motor parameter written to while motor control is operational.	Recycle keyswitch to allow parameters to be reloaded correctly.
14	3 <sup>rd</sup> Party Anonymous Node EMCY received	I / DS / RTB	3 <sup>rd</sup> party node has transmitted an EMCY message.	Check CANbus wiring and 3 <sup>rd</sup> party node status.
15	Vehicle service required	I	Vehicle service interval has expired.	Service vehicle and reset service hours.

Table 7 Fault identification

## Fault list

Use DVT to access the Fault list. If you don't have DVT you can use any configuration tool as follows:

1. Object 5300<sub>n</sub> gives information about all active faults. Read sub-index 1 to get the number of active faults. Write to sub-index 2 to select one of the active faults (0 = highest priority) and read back sub-index 3 to read the fault ID at that index.
3. Object 5610<sub>n</sub> can be used to read a text description of the fault. Write the fault ID to sub-index 1 and read back the fault description from sub-index 2.

## Upgrading the controller software



It is possible to field update the firmware of the Gen4 controller , typically using Sevcon's DVT configuration tool.

Please contact Sevcon for assistance with this process.



